

KATANIA

20

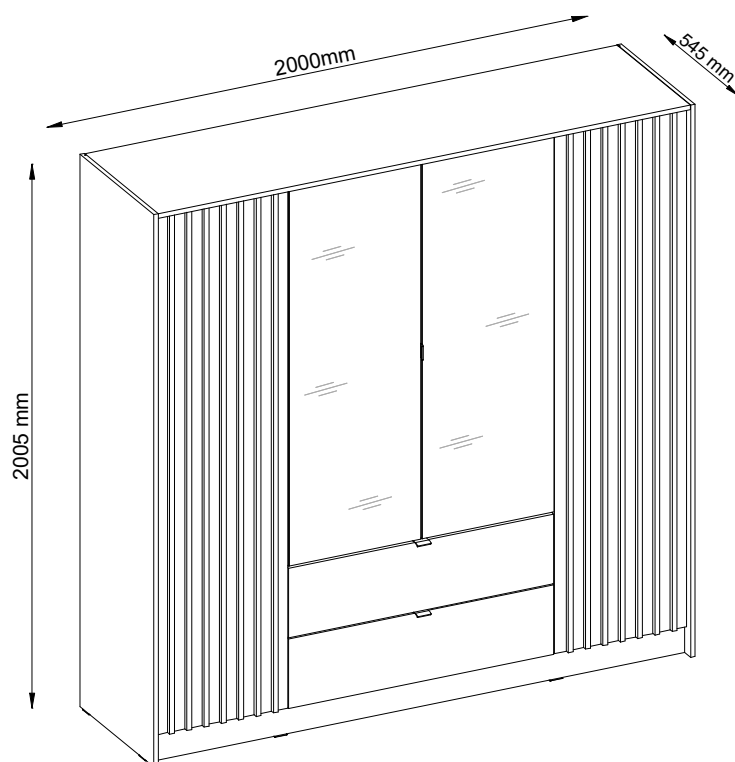

- | | | |
|--|---|--|
| D Montageanleitung
Kleiderschrank >Katania< | GB Assembly instructions
Wardrobe >Katania< | SRB Упутства за инсталацију
Гардеробу >Katania< |
| FR Notice de montage
Armoire >Katania< | IT Intruzioni di montaggio
Armadio >Katania< | HR Upute za instalaciju
Ormar >Katania< |
| NL Handleiding voor de montage
Kast >Katania< | PL Instrukcja montażu
Szafa >Katania< | SL Návod na montaž
Kabinet >Katania< |
| CZ Montážní návod
Kabinet >Katania< | SK Návod na montáž
Skriňa >Katania< | LT Surinkimo instrukcijos
Kabinetas >Katania< |
| HU Szerelési útmutató
Szekrény >Katania< | RO Instructiuni de montaj
Cabinet >Katania< | LV Montāžas instrukcija
Ministru kabinets >Katania< |
| TR Montaj talinatl
Dolap >Katania< | RU Инструкция по монтажу
Шкаф >Katania< | EE Kokkupaneku juhised
Kabinet >Katania< |
| ES Instrucciones de montaje
Armario >Katania< | PT Instruções de montagem
Guarda-roupa >Katania< | |

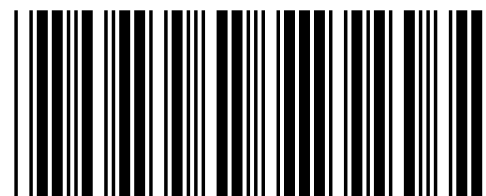
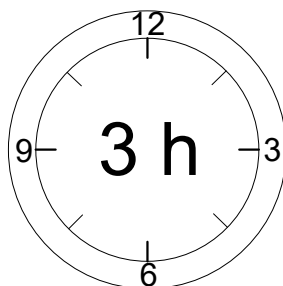
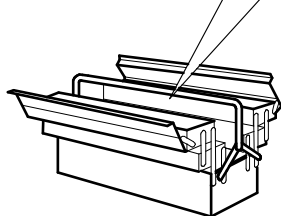
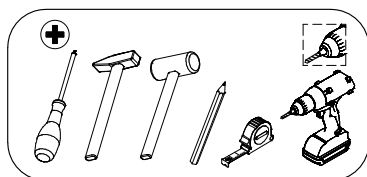
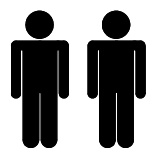

* 2 8 0 7 8 5 *

D-Ziehen Sie alle Schrauben sowie tragende Verbindungsteile nach ca. 5 Wochen nach, um einedauerhafte Standsicherheit zu gewährleisten.

GB-After approx. 5 weeks, tighten all screws and load-bearing connecting parts to ensure permanent stability.

FR-Resserrez toutes les vis ainsi que les pièces de fixation au bout d'environ 5 semaines pour garantir une sécurité de fixation durable.

IT- Ristringere tutte le viti e giunture dopo ca. 5 settimane, al fine di garantire una durevole solidità.

NL-Draai alle schroeven en ook dragende verbindingstukken na ca. 5 weken nog eens vast, zodateen continue stabiliteit wordt gegarandeerd.

PL-Prosimy po ok. 5 tygodniach dokręcić wszystkie śruby i elementy łączeniowe. Zagwarantuje to Państwu trwałość i stabilność połączeń.

CZ- Dotáhněte všechny šrouby a nosné spojovací díly přibližně po 5 týdnech, aby se zaručila trvalá stabilita.

SK-Po cca 5 týždňoch dotiahnite skrutky, aby bola zaručená ich trvalá stabilita.

HU-Húzza utána - kb. 5 hét múlva - az összes csavart és a teherhordó összekötő-alkatrészeket abiztonság érdekében.

RO-Pentru a asigura o stabilitate de durată, strângeți după cca. 5 săptămâni toate șuruburile, precumși toate elementele portante de legătură.

TR-Tüm vida ve taşıyıcı bağlantı parçalarını kalıcı bir duruş güvenliğini sağlamak için yaklaşık 5 haftasonra tekrar sıkınız.

RU - Подкрутите все болты, а также несущие соединительные детали припл. через 5 недель для обеспечения устойчивости в течение длительного времени.

SRB - Молим вас после акрокса. 5 недеља затегните све шрафове и причвршћиваче. То ће вам гарантовати трајност и стабилност веза.

HR - Molim vas, nakon cca. 5 tjedana zategnite sve vijke i pričvršćivače. To će vam jamčiti trajnost i stabilnost priključaka.

SL - Pýtame sa po cca. 5 týždňov utiahnite všetky skrutky a upevňovacie prvky. To zaručuje trvanlivosť a stabilitu spojov.

LT - Mes prašome po maždaug. 5 savaites priveržkite visus varžtus ir tvirtinimo detales. Taip užtikrinamas jungčių patvarumas ir stabilumas.

LV - Mēs lūdzam pēc apm. 5 nedēļas, pievelciet visas skrūves un stiprinājumus. Tas garantē savienojumu izturību un stabilitāti.

EE - Küsime pärast ca. 5 nädalat, pingutage kõiki kruvisid ja kinnitusi. See tagab ühenduste vastupidavuse ja stabiilsuse.

ES - Apriete todos los tornillos y elementos de conexión después de aprox. 5 semanas. Esto le garantizará la durabilidad y estabilidad de sus conexiones.

PT - Aperte todos os parafusos e elementos de ligação após aprox. 5 semanas. Isto garantirá a durabilidade e a estabilidade das suas ligações.

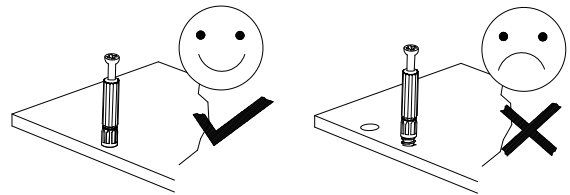

D Bitte nur mit einem Staubtuch oder leicht feuchtem Lappen reinigen. Keine scheuernden Putzmittel verwenden.

GB Please only clean with a duster or a damp cloth. Do not use any abrasive cleaners.

FR Veuillez nettoyer uniquement avec un chiffon à poussière ou un chiffon légèrement humide. N'pas utiliser de détergent abrasif.

IT Si raccomanda di pulire solo con un panno per la polvere o uno strofinaccio umido. Non utilizzare detergenti abrasivi.

NL Reinig alleen met een stofdoek of een lichtjes vochtige doek. Gebruik geen schurende poetsmid-delen.

PL Czyszczenie należy wykonać wyłącznie za pomocą ściereczki lub lekko nawilżonego ręcznika. Nie stosować środków czyszczących do szorowania.

CZ Čistěte prosím jen prachovkou nebo lehce navlhčeným hadrem. Nepoužívejte drhňoucí čisticí prostředky.

SK Na čistenie používajte len prachovku alebo zľahka navlhčenú utierku. Nepoužívajte žiadne drhňúce čistiace prostriedky.

HU Kérjük, csak portórló kendővel vagy enyhén nedves ronggyal tisztítsa. Ne használjon dörzshatású tisztítószeret.

RO Vă rugăm să utilizați la curățare exclusiv o cârpă de șters praful sau o cârpă ușor umezită. Nu utilizați substanțe de curățat abrazive.

TR Lütfen sadece bir toz bezyle veya hafif nemli yumuşak bir bezle siliniz. Aşındırıcı temizlik malze-meleri kullanmayınız.

RU Для чистки используйте, пожалуйста, тряпку для пыли или слегка влажную ветошь. Неиспользовать абразивные чистящие средства.

SBR Чишћење треба обавити само крпом или благо влажним пешкиром. Немојте користити средство за чишћење рибанја.

HR Čišćenje treba obaviti samo krpom ili blago navlaženim ručnikom. Ne koristite sredstva za čišćenje ribanja.

SL Čistenie by sa malo vykonávať len handričkou alebo ľahko navlhčeným uterákom. Nepoužívajte čistiace prostriedky na drhnutie.

LT Valyti galima tik šluoste arba lengvai sudrėkintu rankšluosčiu. Nenaudokite šveičiamųjų valiklių.

LV Tīrīšana jāveic tikai ar drānu vai viegli samitrinātu dvieli. Neizmantojiet tīrīšanas līdzekļus.

EE Puhastada tohib ainult lapiga või kergelt niisutatud rätikuga. Ärge kasutage puhastusvahendeid.

PT A limpeza deve ser feita apenas com um pano ou toalha ligeiramente húmida. Não utilize produtos de limpeza abrasivos.

ES La limpieza debe realizarse únicamente con un paño o toalla ligeramente húmedo. No utilice agentes de limpieza abrasivos.

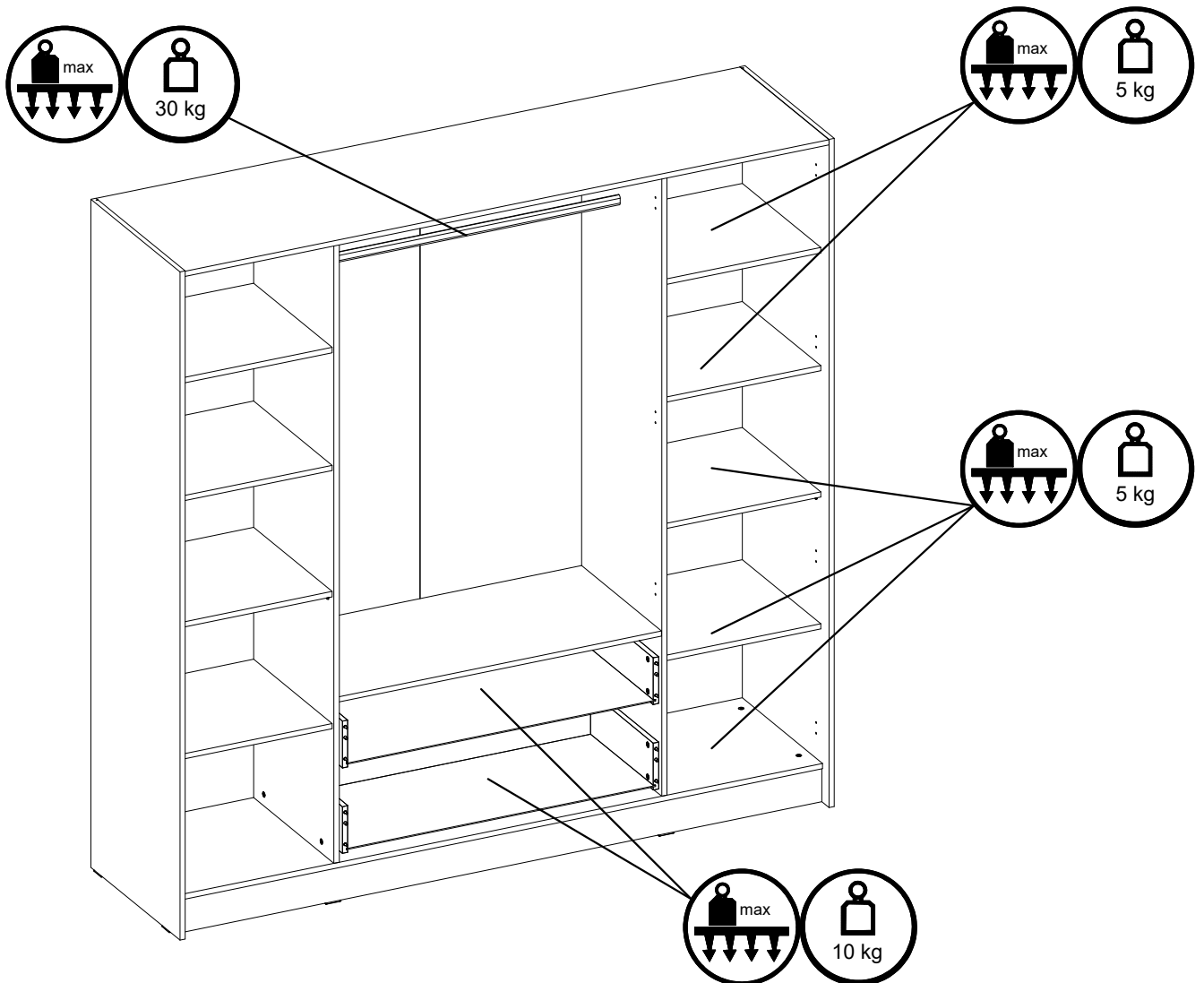
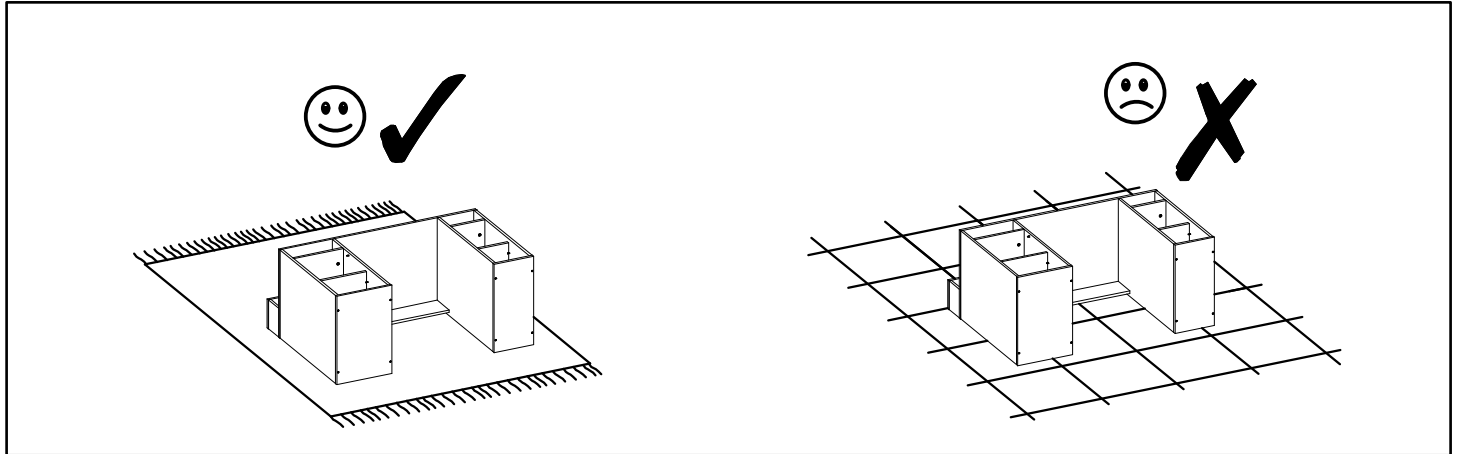
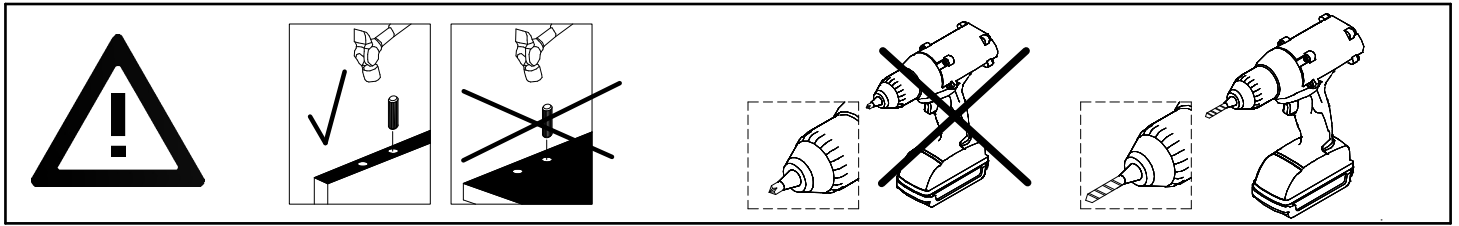
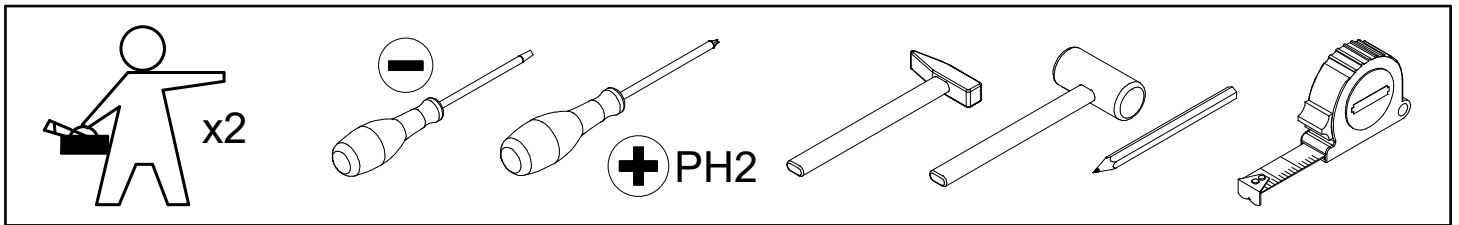

Service · Assistenza · Dienstverlening · Serwis Servis · Szerviz · Сервисная служба · Сервис · Serwis · Servis

Name · Nom · Nome · Naam ·
 Nazwa · Jméno · Názov · Név ·
 Denumire · Isim · Название

KATANIA

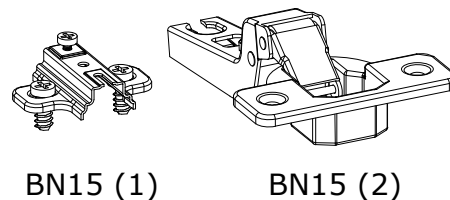
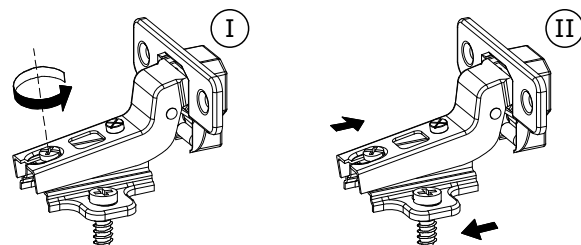
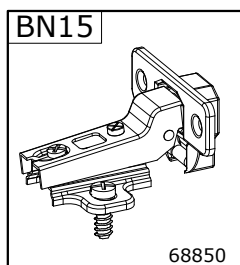
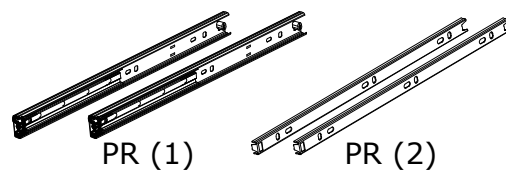
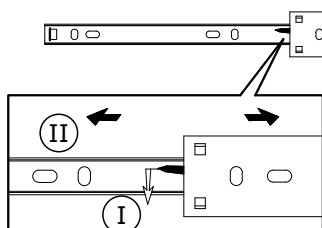
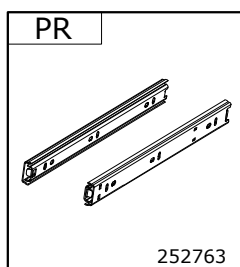
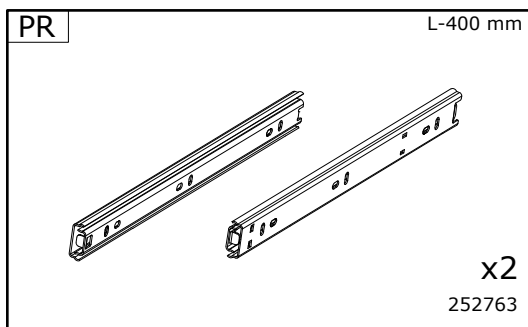
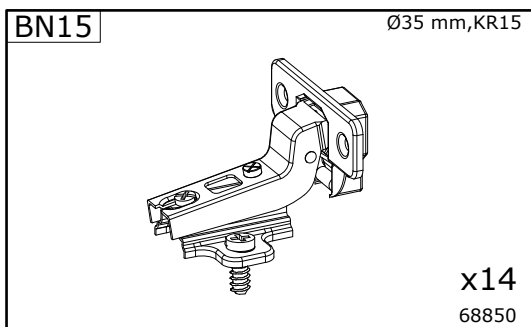
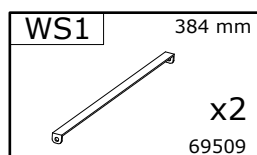
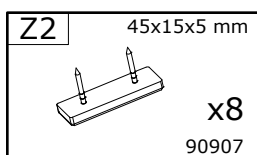
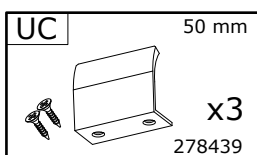
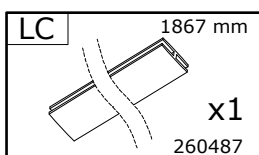
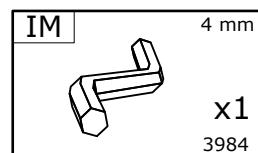
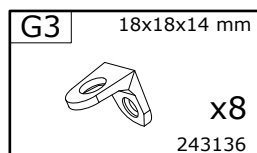
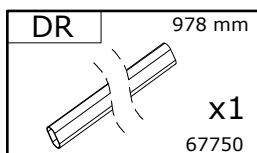
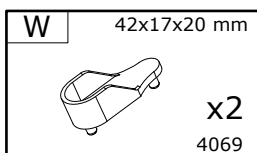
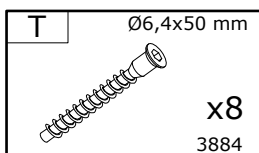
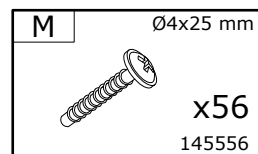
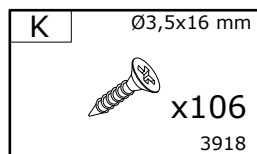
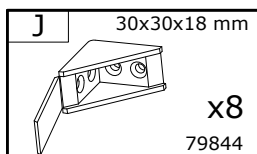
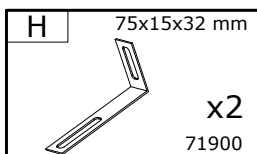
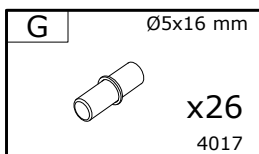
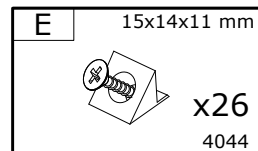
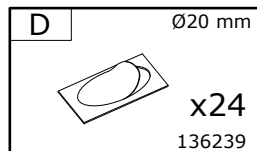
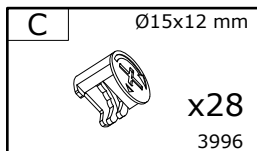
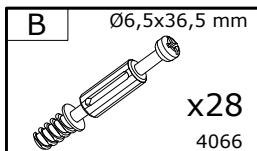
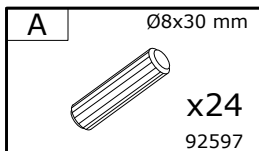
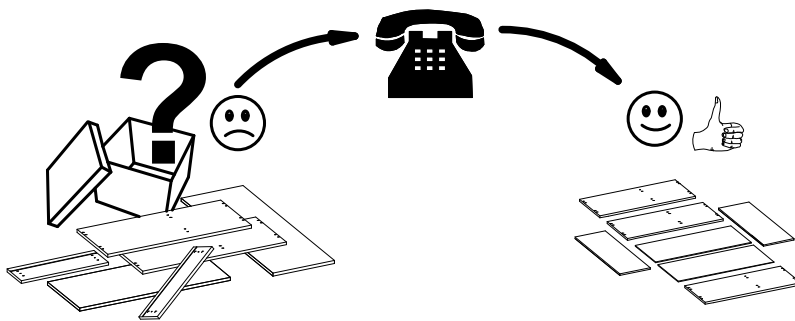
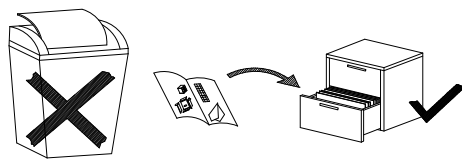

Typ · Type · Tip · Típus · Тіро ·
 Тип

20

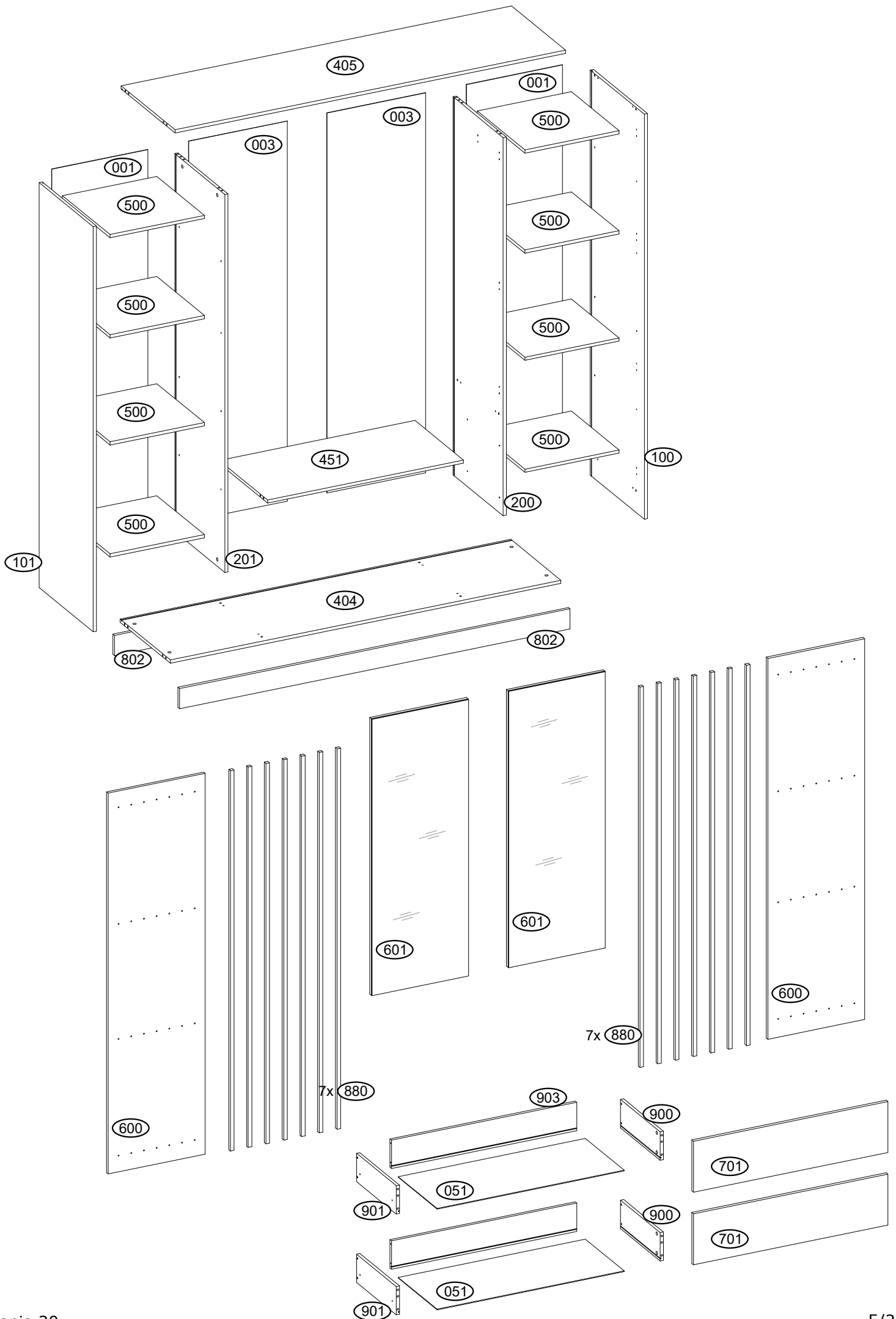

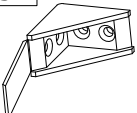

1

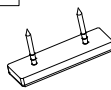
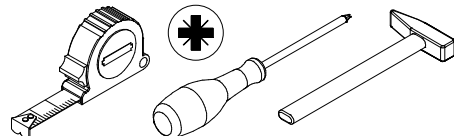
J 30x30x18 mm  x8 79844	K Ø3,5x16 mm  x32 3918	Z2 45x15x5 mm  x4 90907	
--	---	--	--

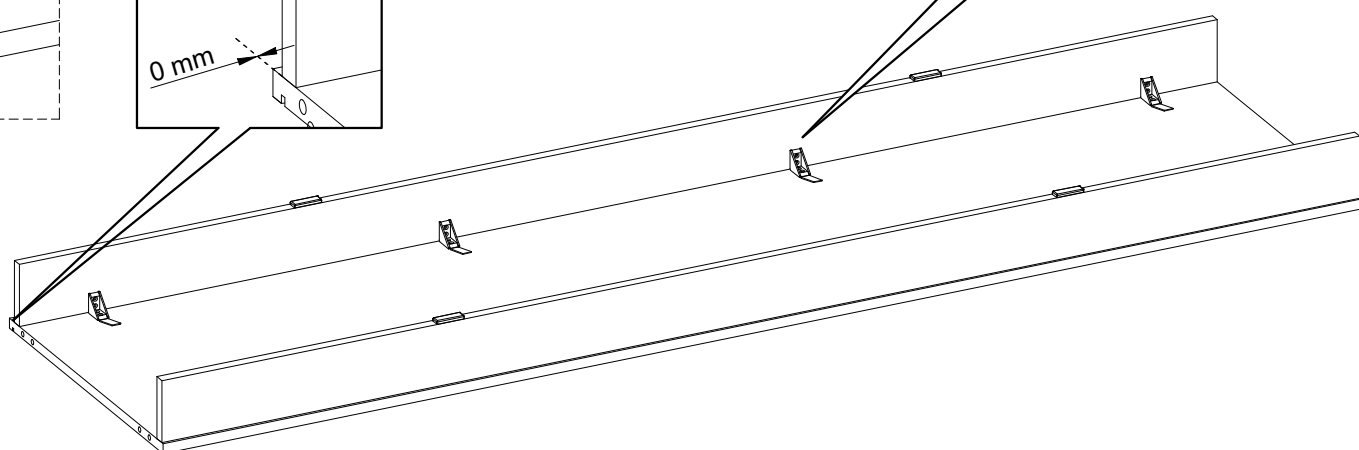
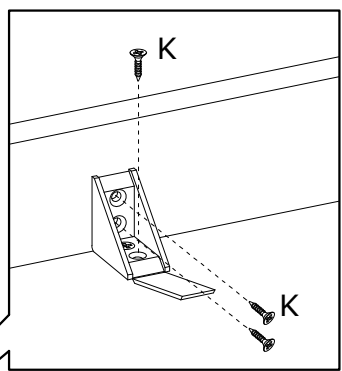
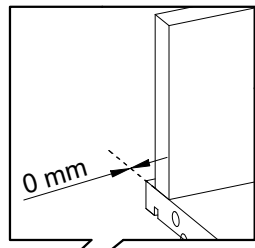
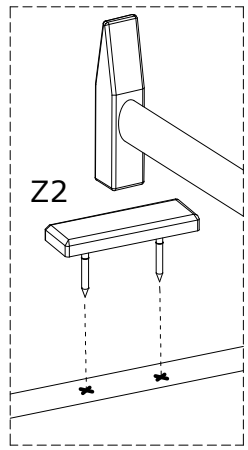
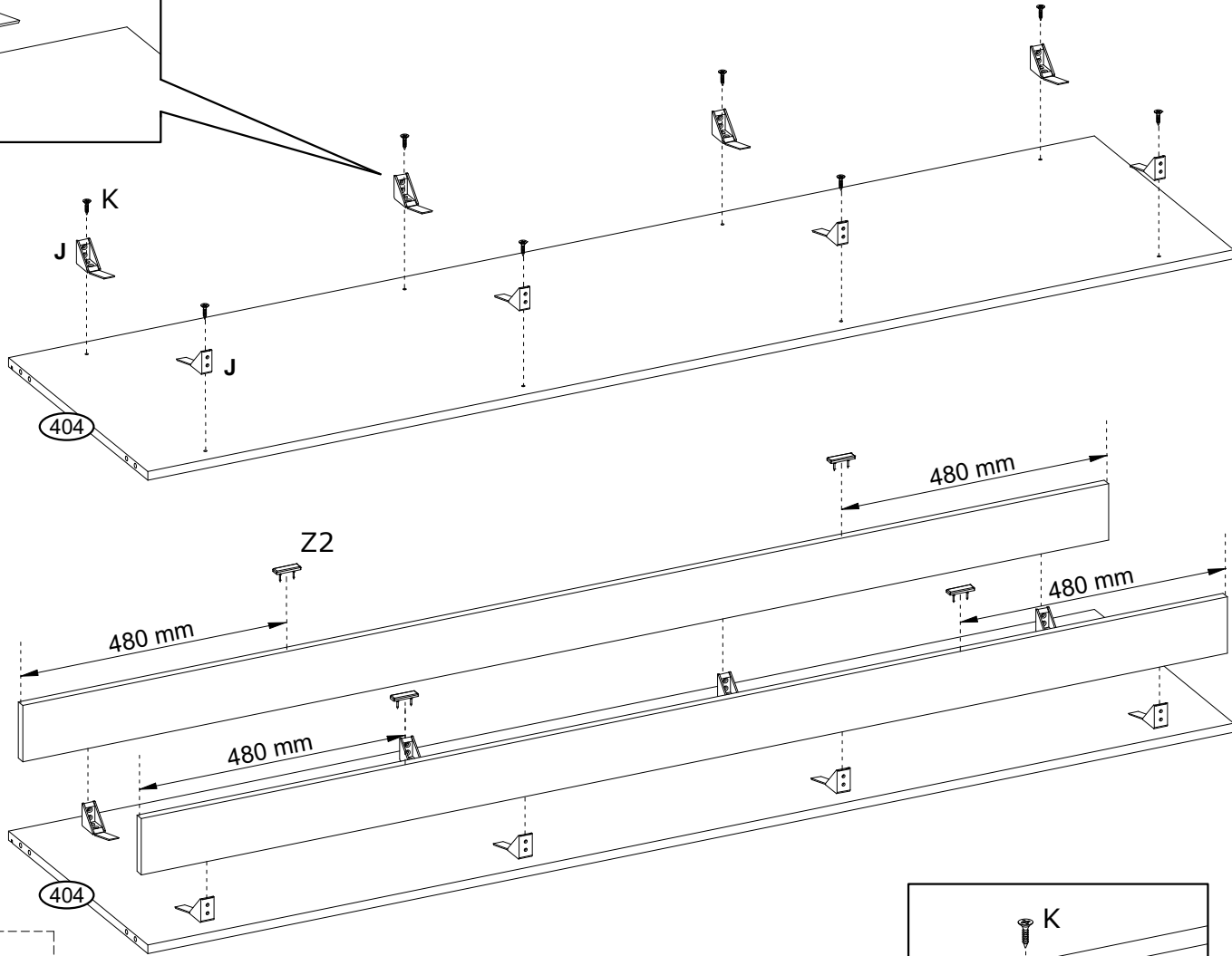
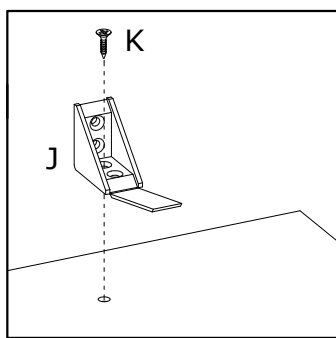

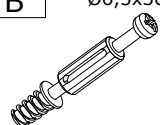

2

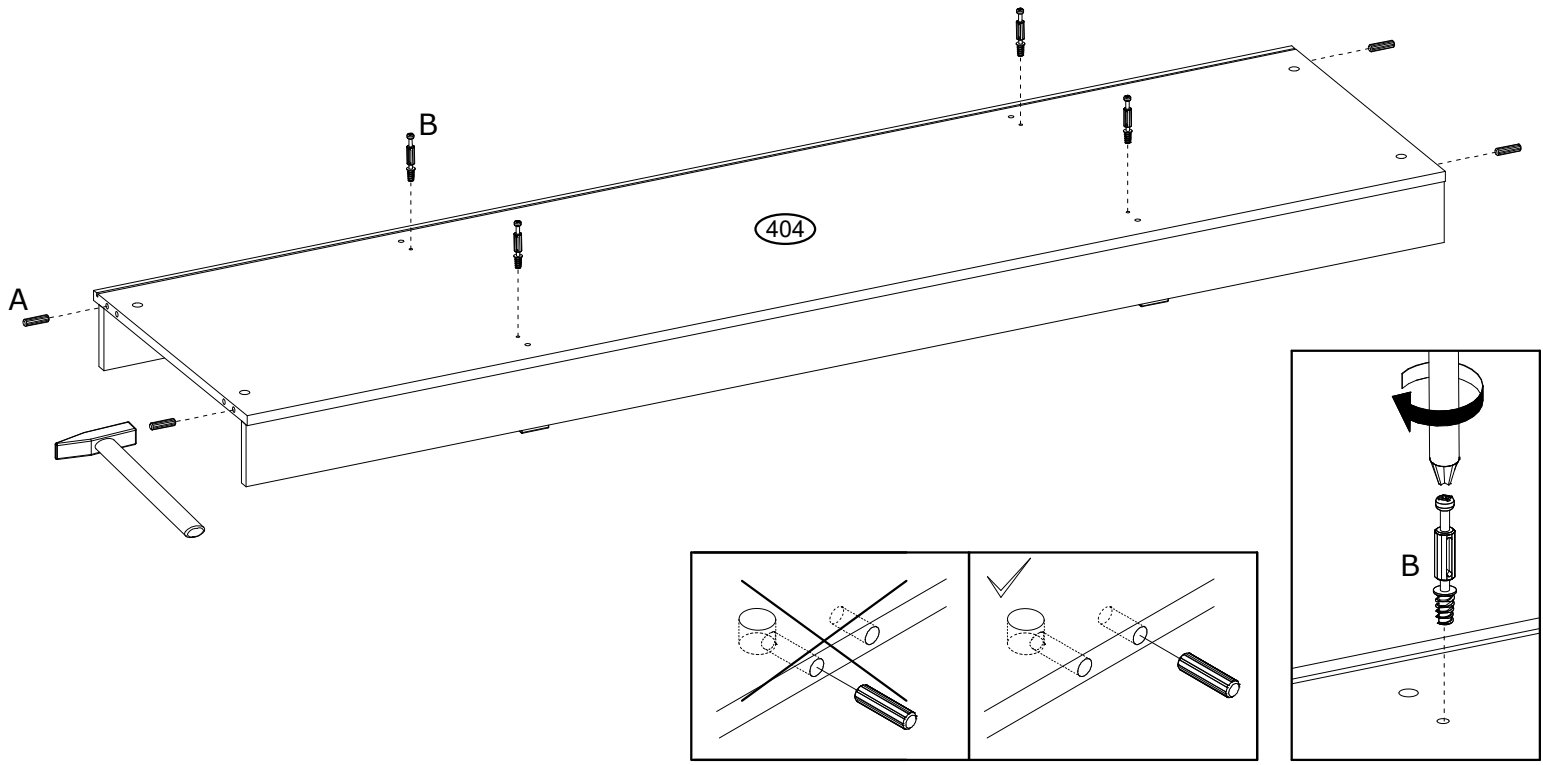
A $\varnothing 8 \times 30$ mm  x4 92597	B $\varnothing 6,5 \times 36,5$ mm  x4 4066	
--	---	--

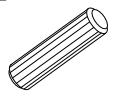
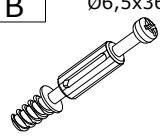

3

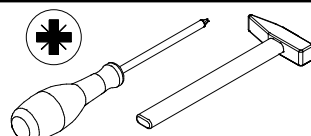
A $\varnothing 8 \times 30$ mm  x4 92597	B $\varnothing 6,5 \times 36,5$ mm  x4 4066	G $\varnothing 5 \times 16$ mm  x2 4017	
---	--	--	---

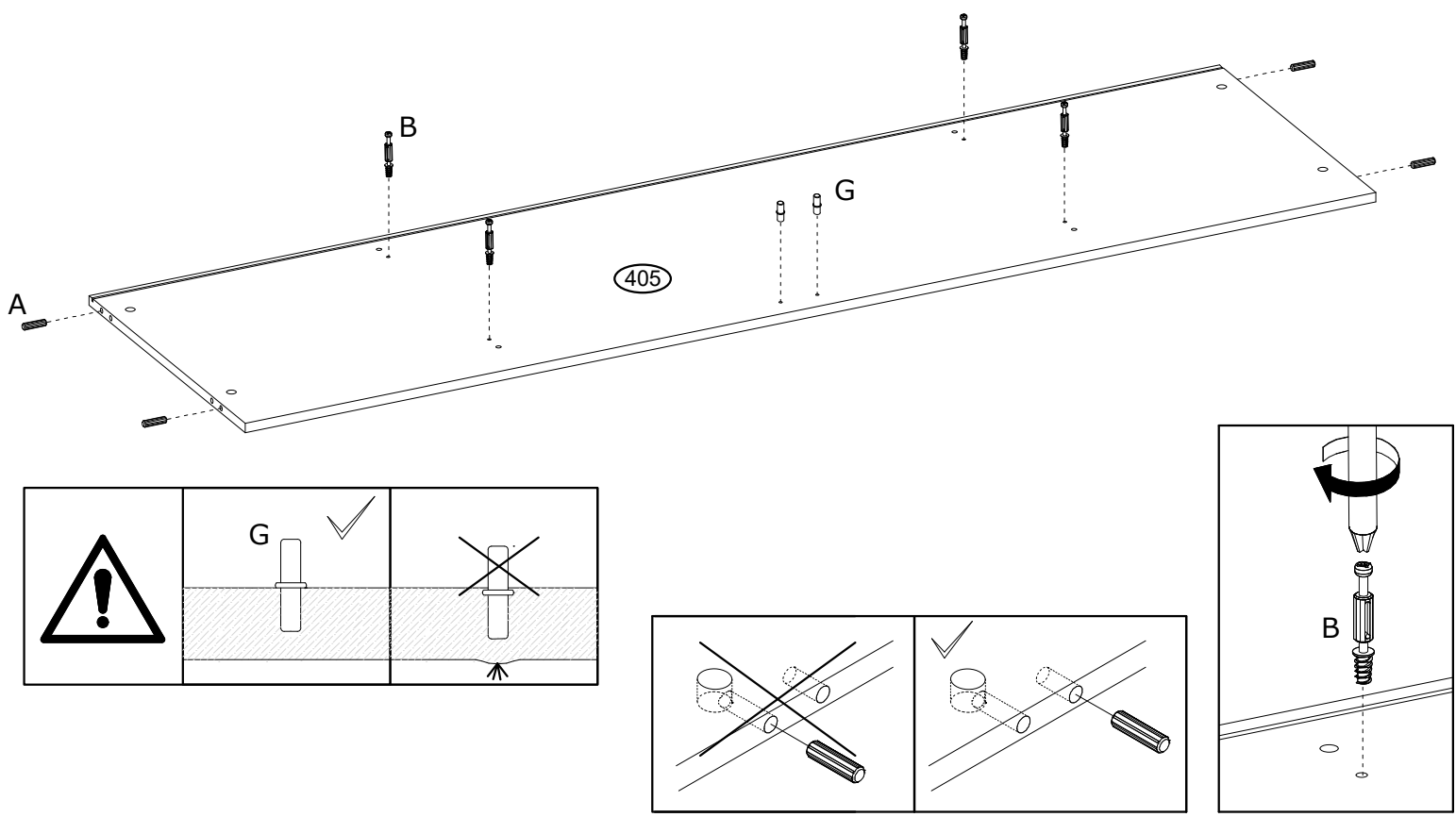

4

B	∅6,5x36,5 mm	K	∅3,5x16 mm	G3	18x18x14 mm	Z2	45x15x5 mm	
	x4 4066		x2 3918		x2 243136		x2 90907	

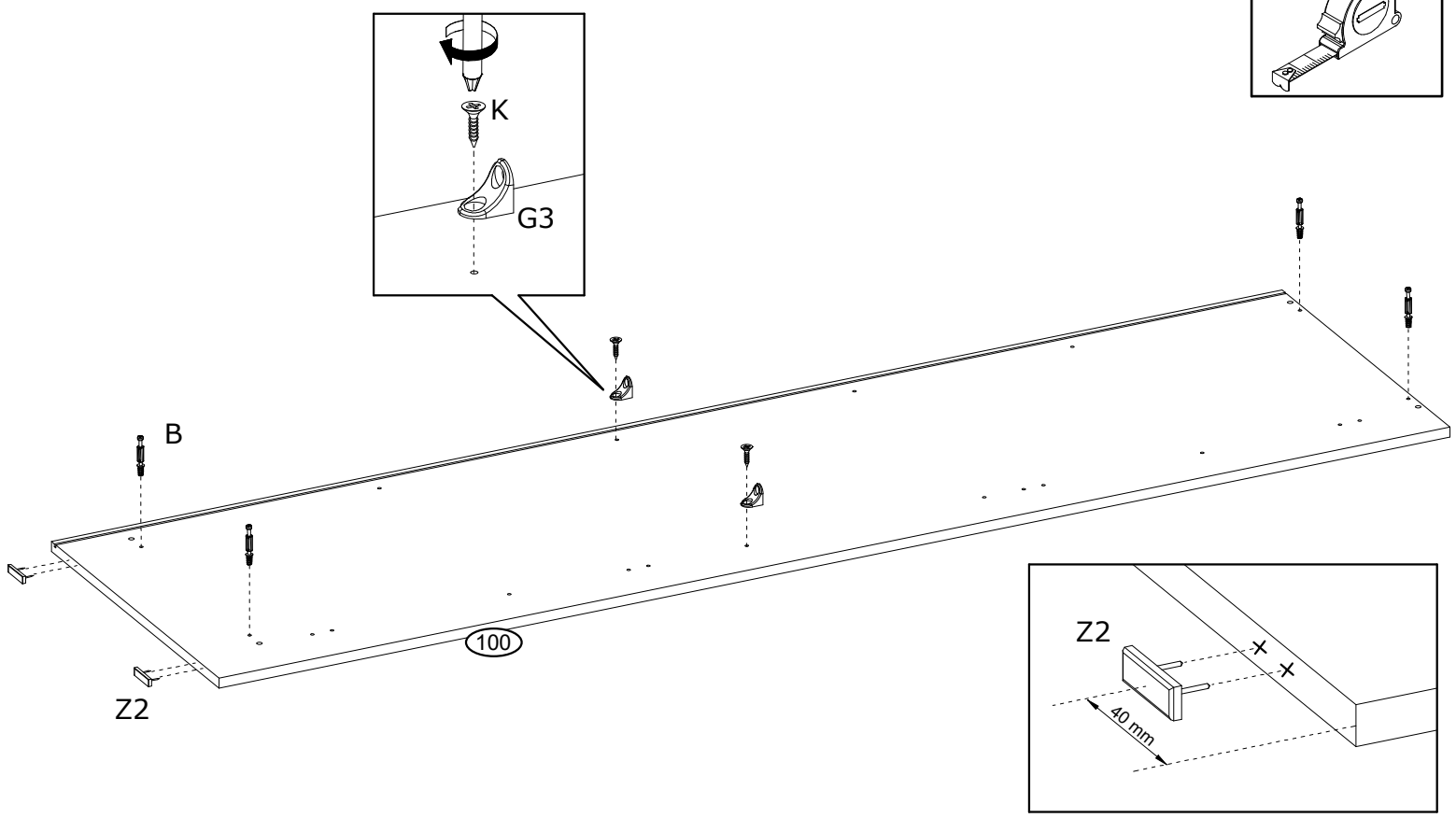

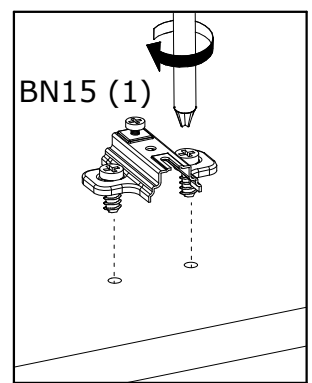
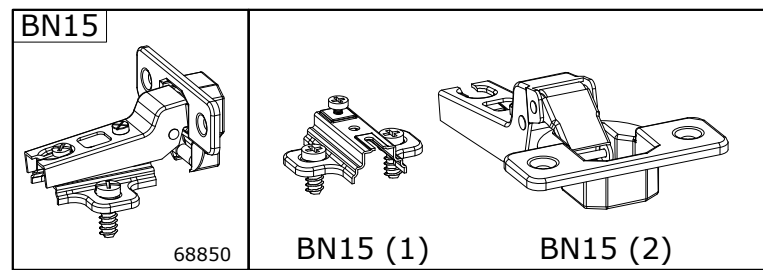
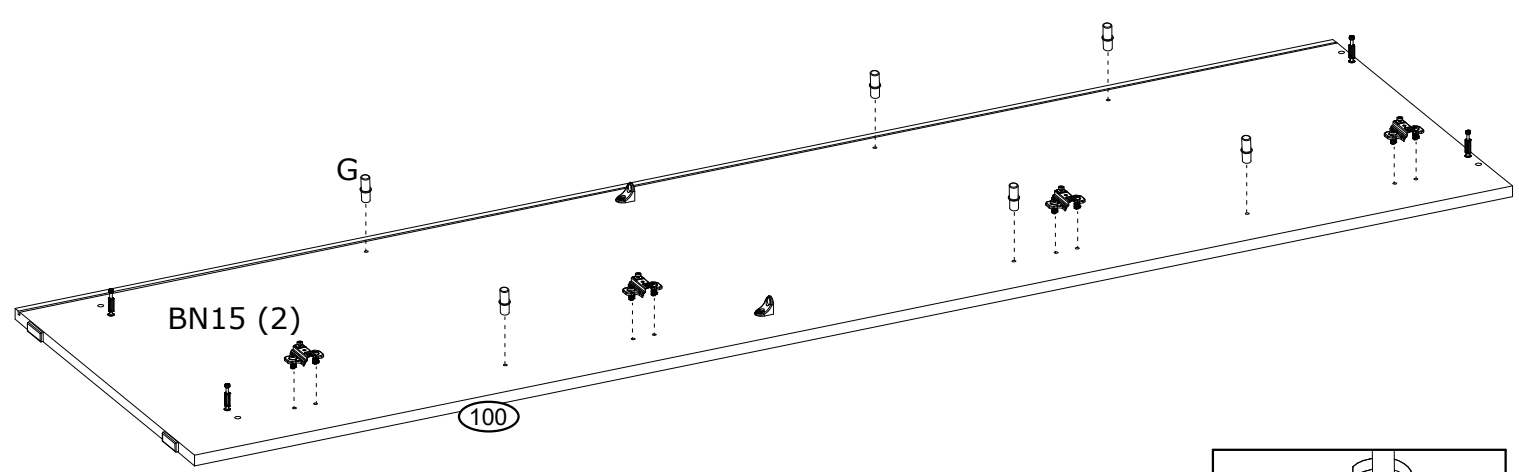

5

G	∅5x16 mm	BN15	∅35 mm, KR15	
	x6 4017		x4 68850	



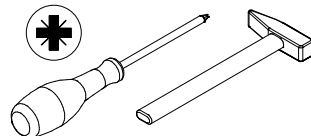
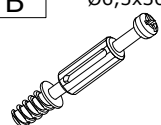

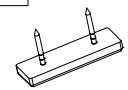
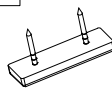
6

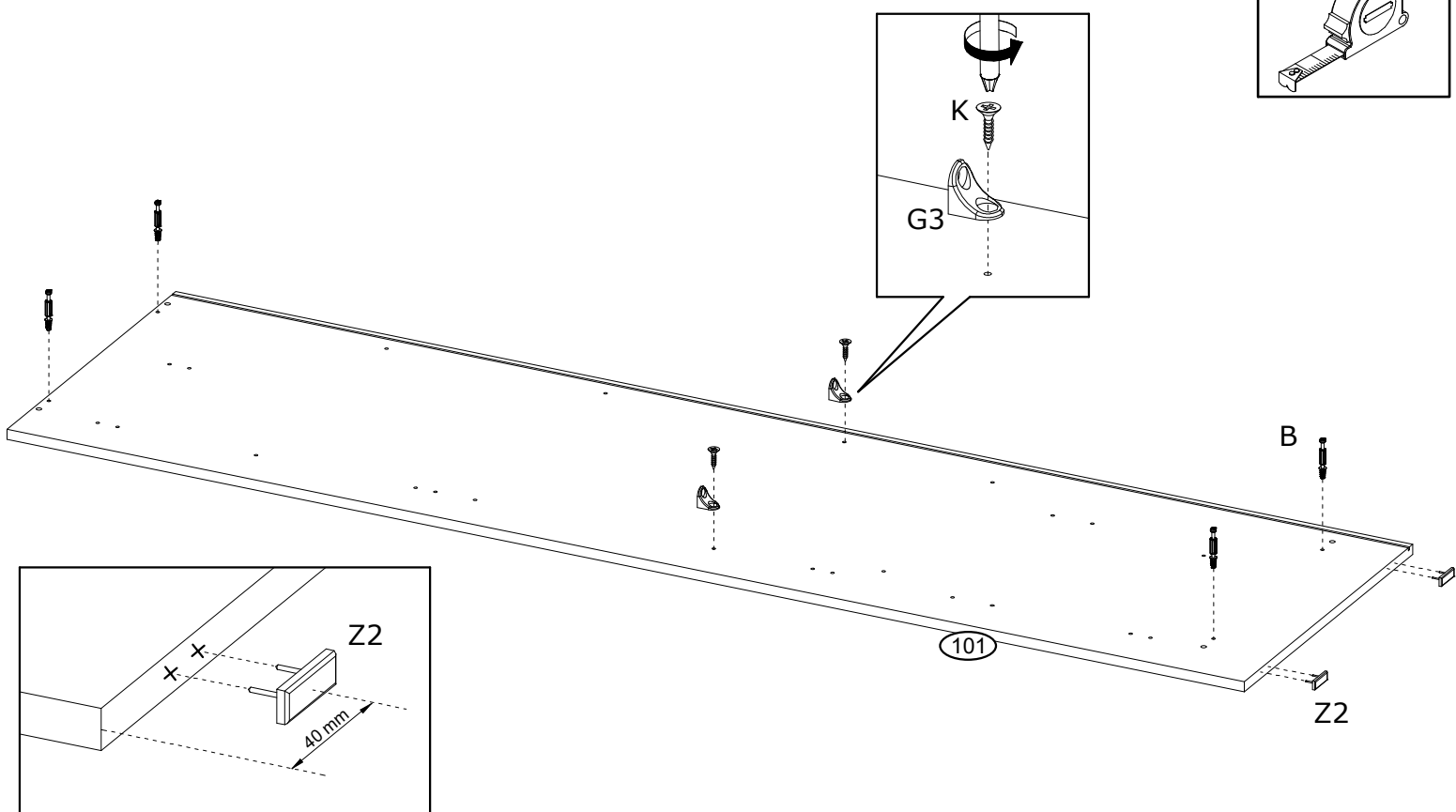
B $\varnothing 6,5 \times 36,5$ mm	K $\varnothing 3,5 \times 16$ mm	G3 18x18x14 mm	Z2 45x15x5 mm	
 x4 4066	 x2 3918	 x2 243136	 x2 90907	



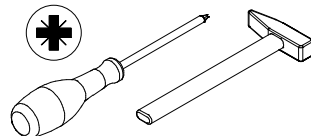

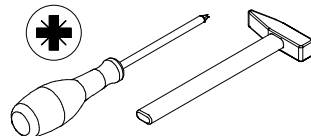

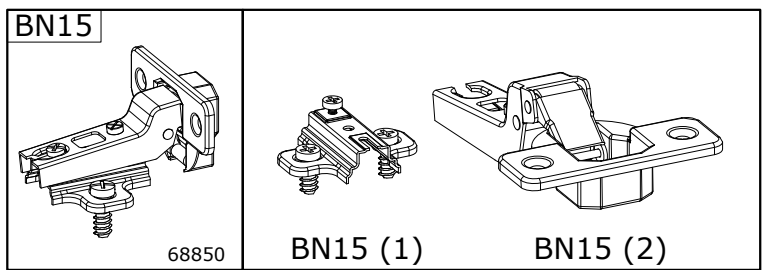
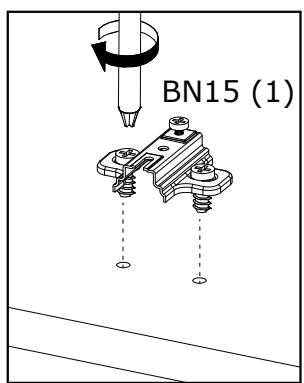
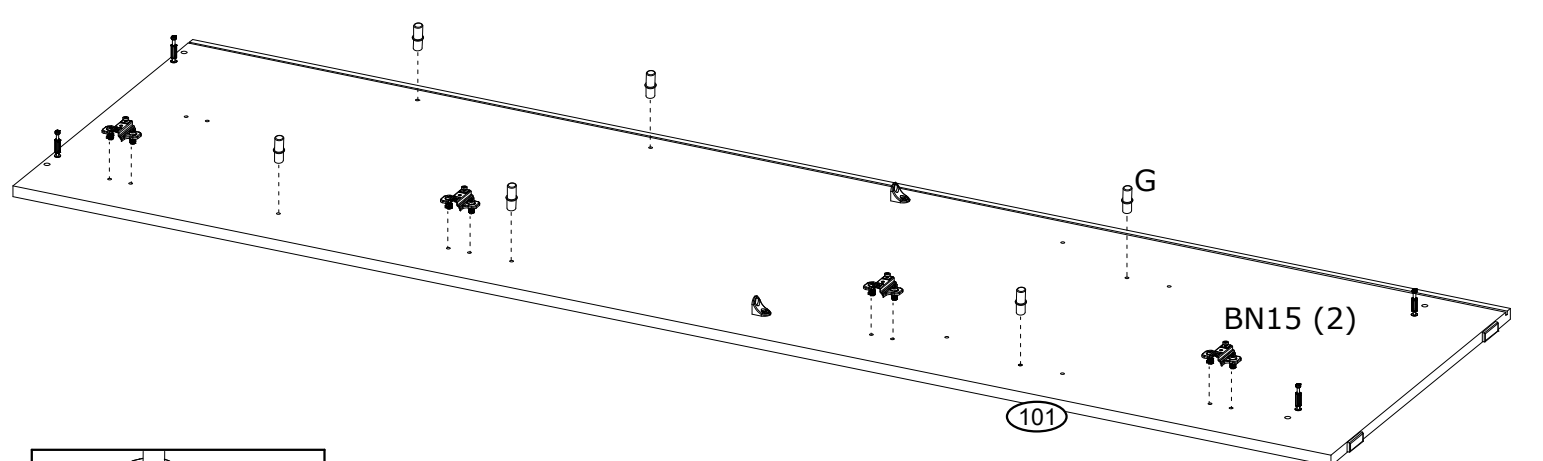

7

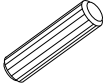
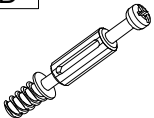
G $\varnothing 5 \times 16$ mm	BN15 $\varnothing 35$ mm, KR15	
 x6 4017	 x4 68850	

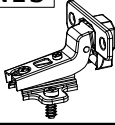

8

A Ø8x30 mm  x4 92597	B Ø6,5x36,5 mm  x2 4066	K Ø3,5x16 mm  x7 3918	G Ø5x16 mm  x6 4017	
W 42x17x20 mm  x1 4069	PR L-400 mm  x2 252763	G3 18x18x14 mm  x2 243136	BN15 Ø35 mm, KR15  x3 68850	

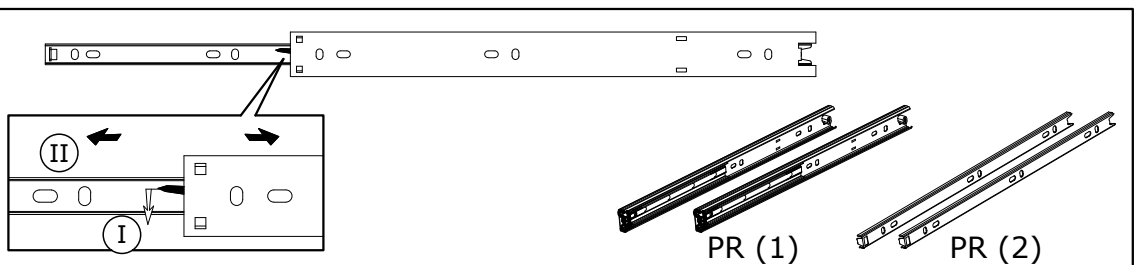
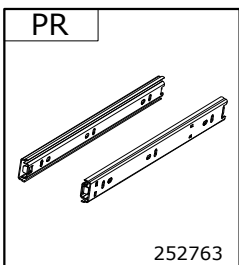
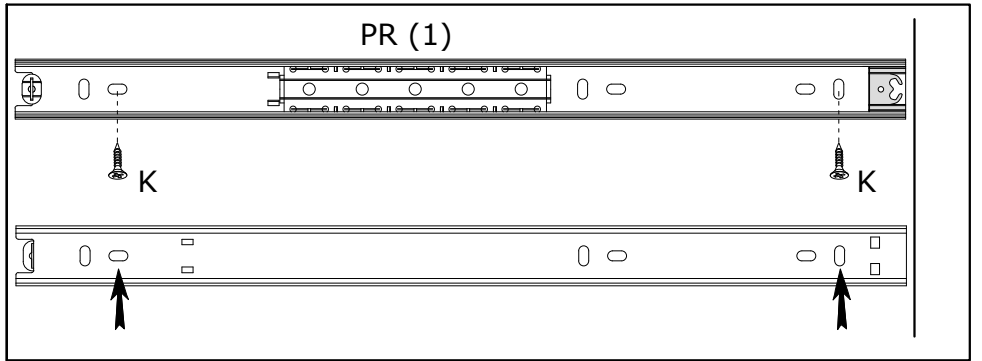
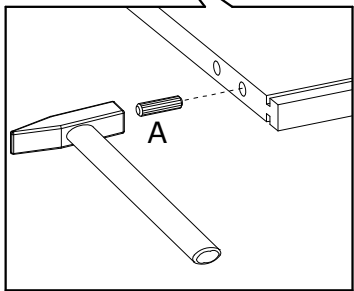
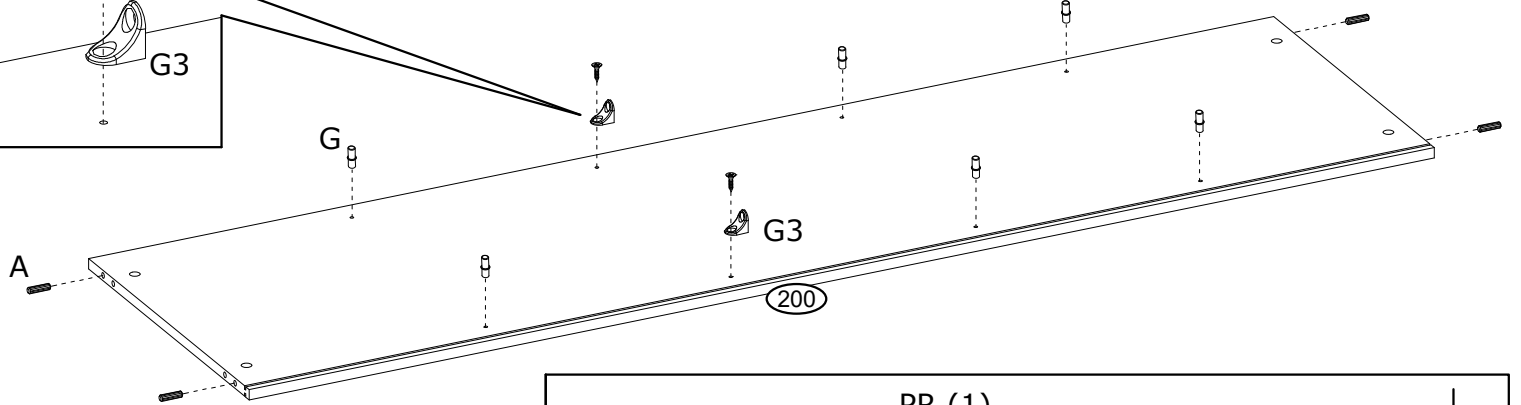
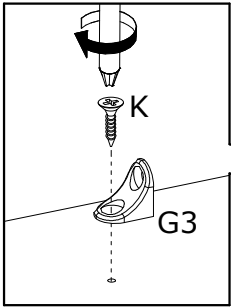
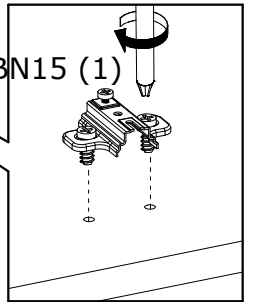
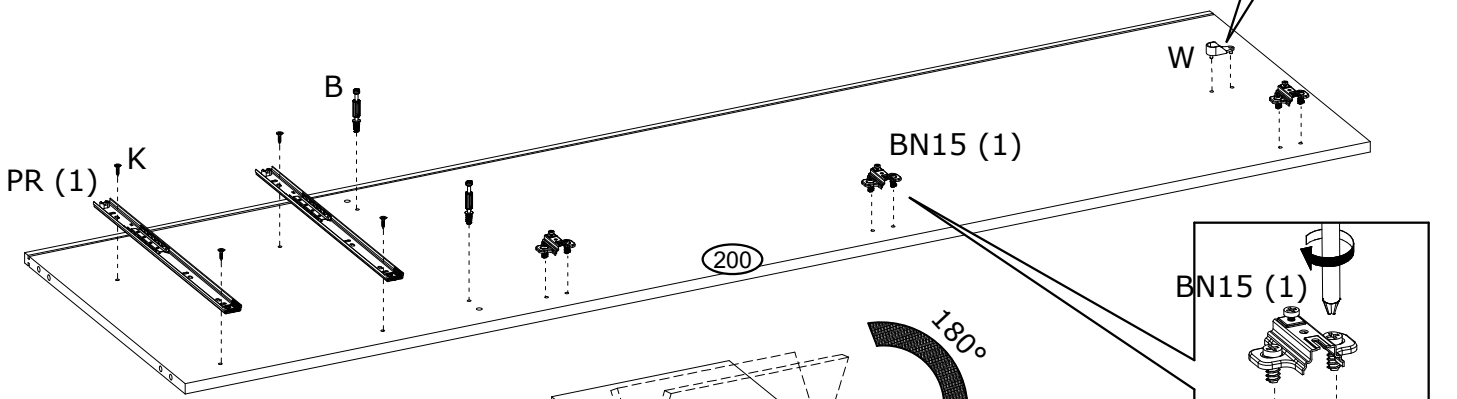
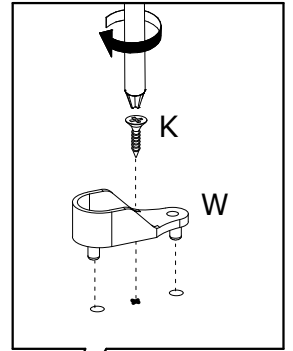

9

A	∅8x30 mm	B	∅6,5x36,5 mm	K	∅3,5x16 mm	G	∅5x16 mm	
	x4 92597		x2 4066		x7 3918		x6 4017	
W	42x17x20 mm	PR	L-400 mm	G3	18x18x14 mm	BN15	∅35 mm, KR15	
	x1 4069		x2 252763		x2 243136		x3 68850	

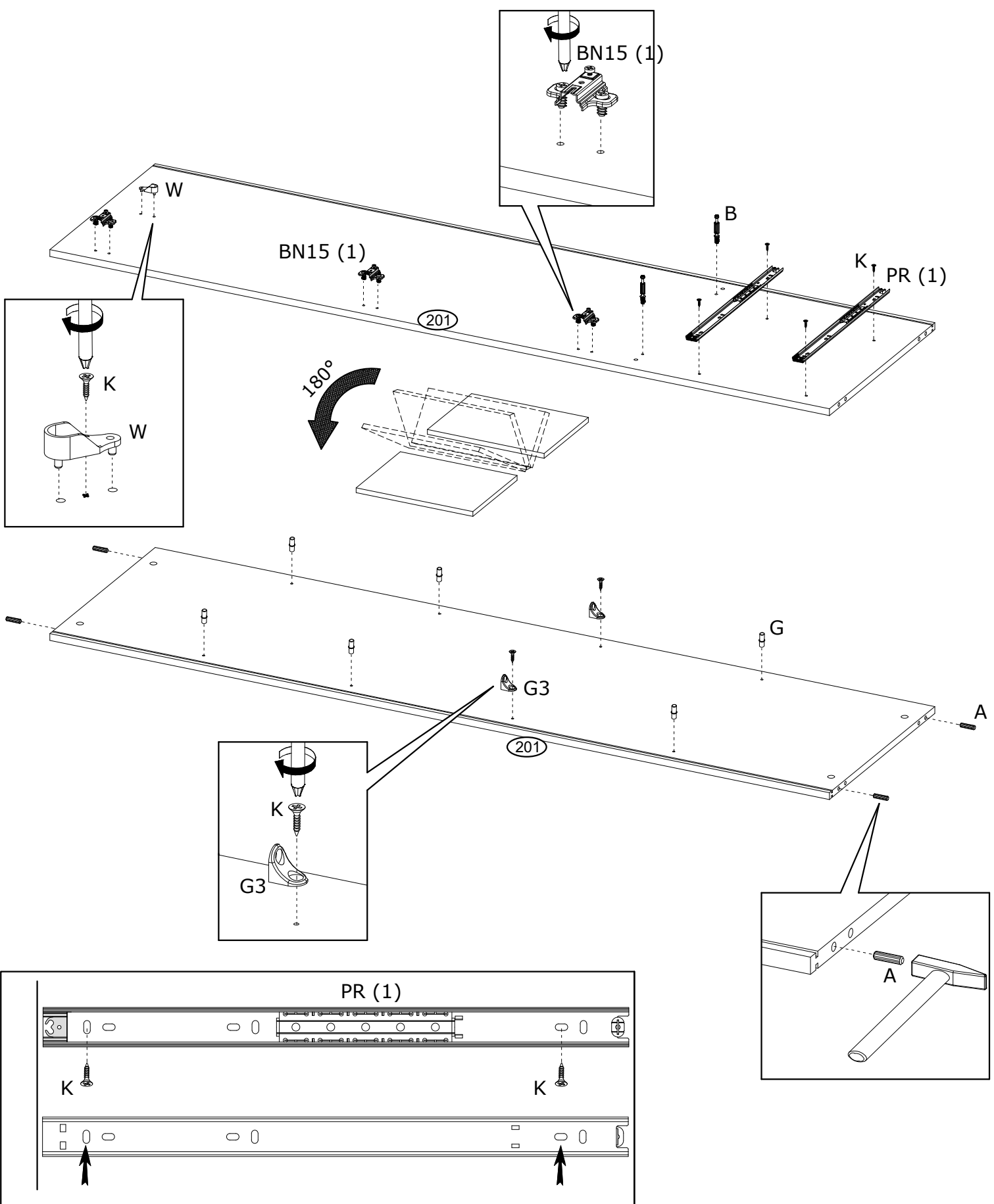

10

A	Ø8x30 mm	x4	92597	
---	----------	----	-------	--

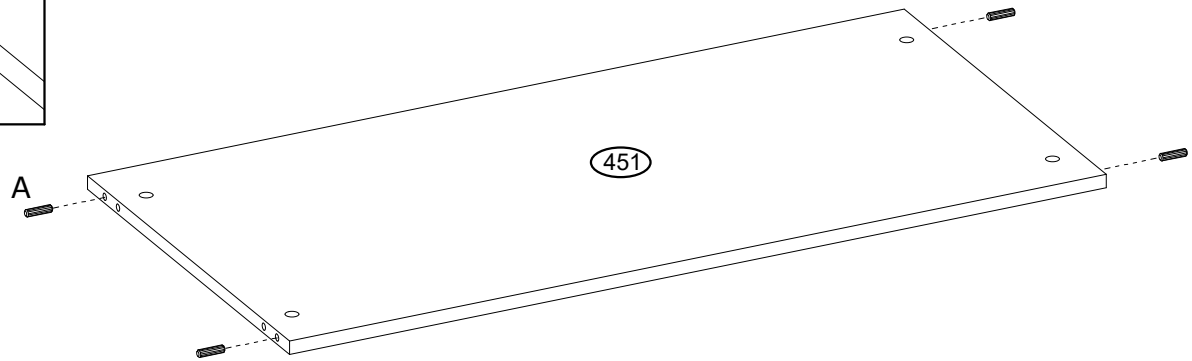
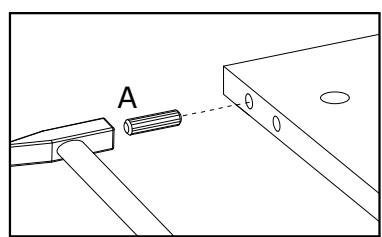

11

C	Ø15x12 mm	x8	3996	
---	-----------	----	------	--

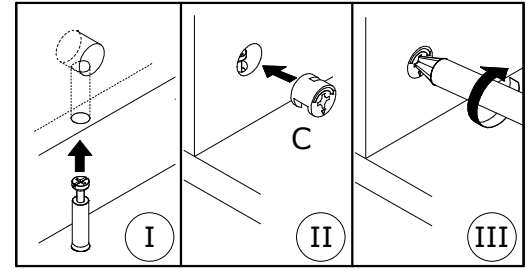
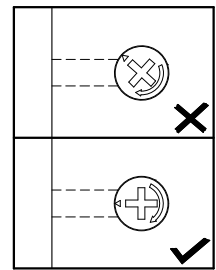
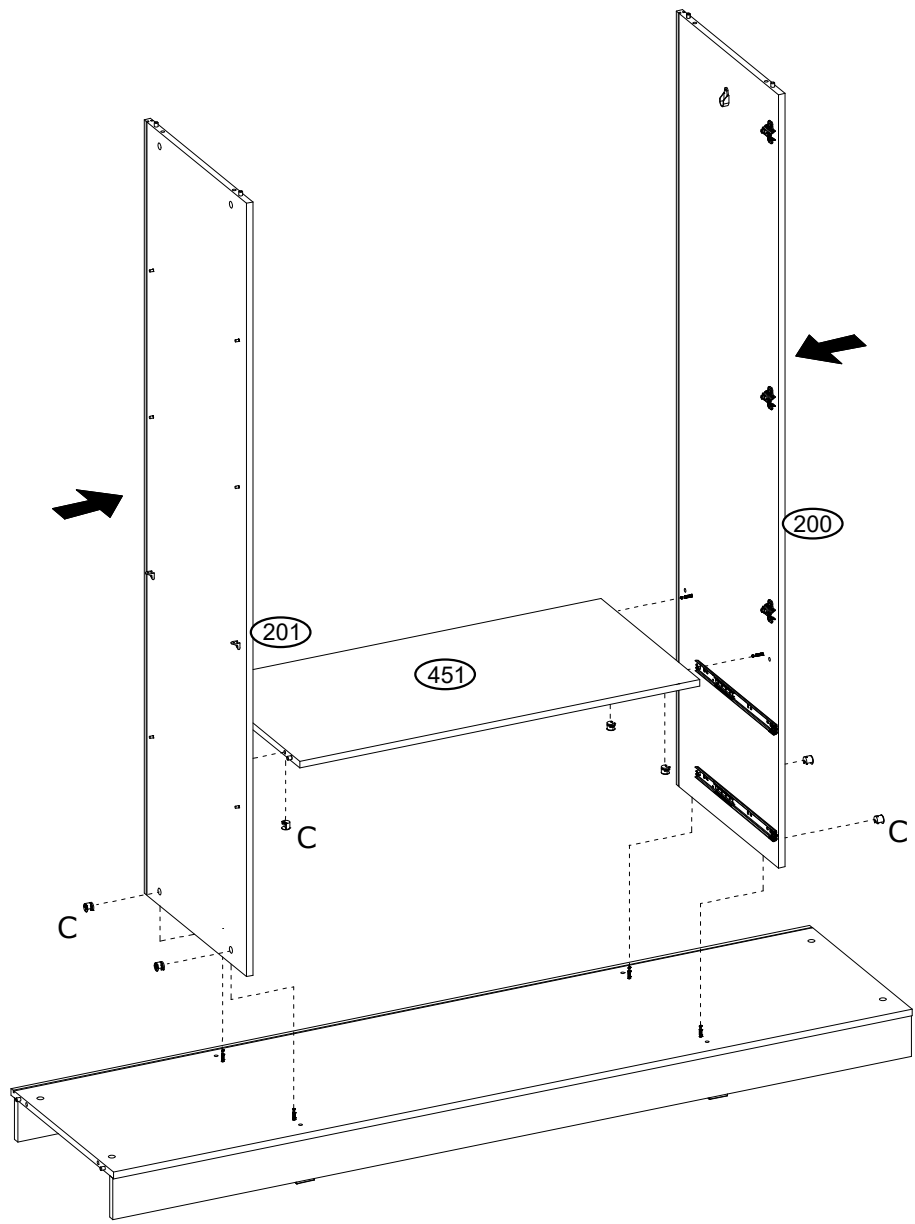

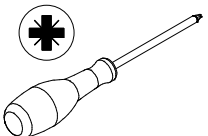

12

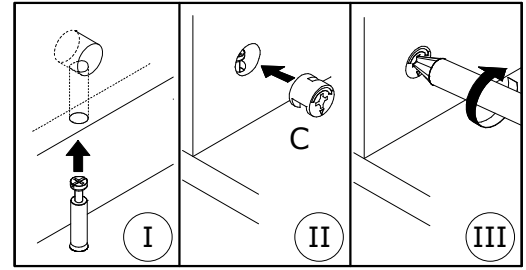
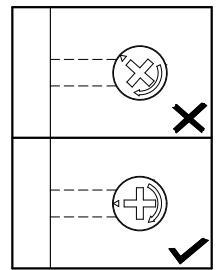
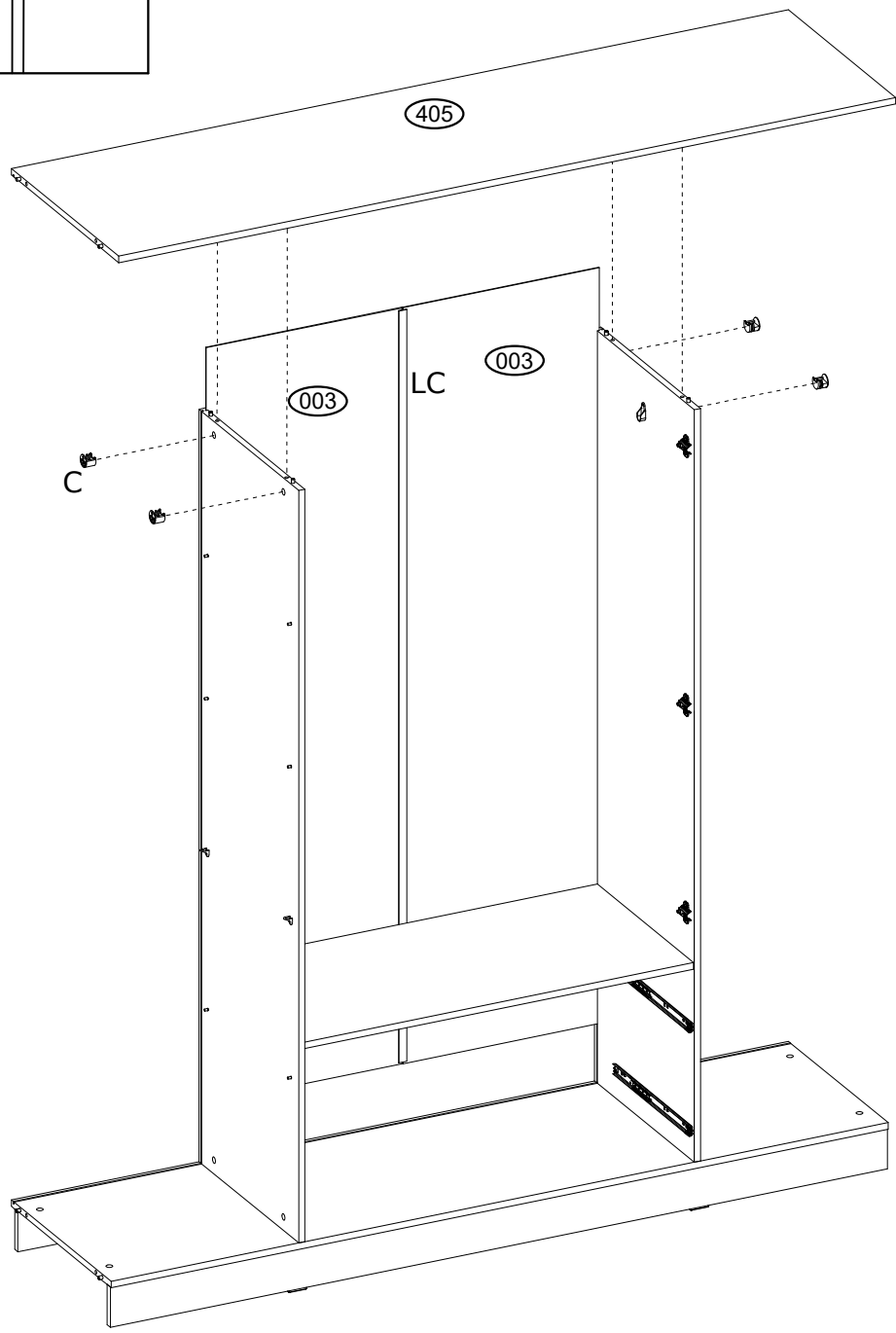
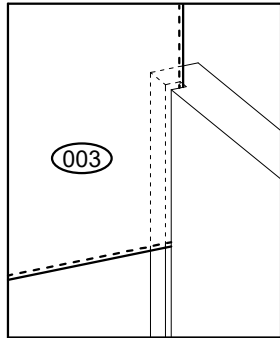
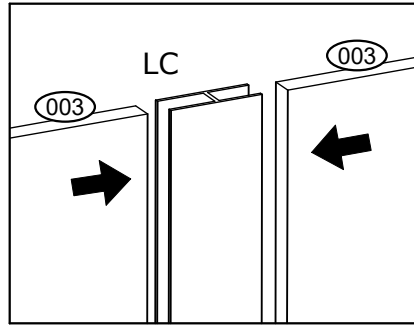
C Ø15x12 mm  x4 3996	LC 1867 mm  x1 260487	
---	--	--

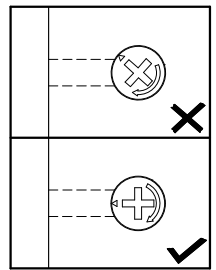
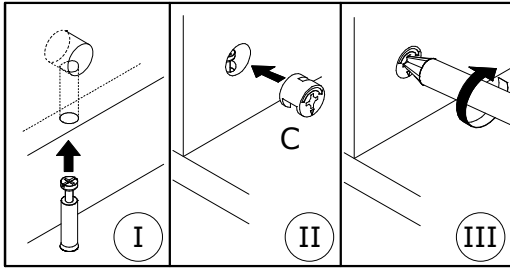
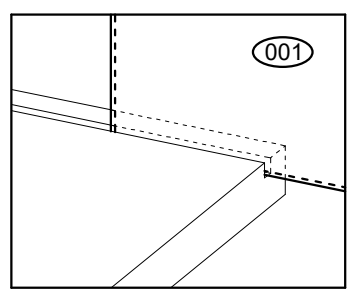
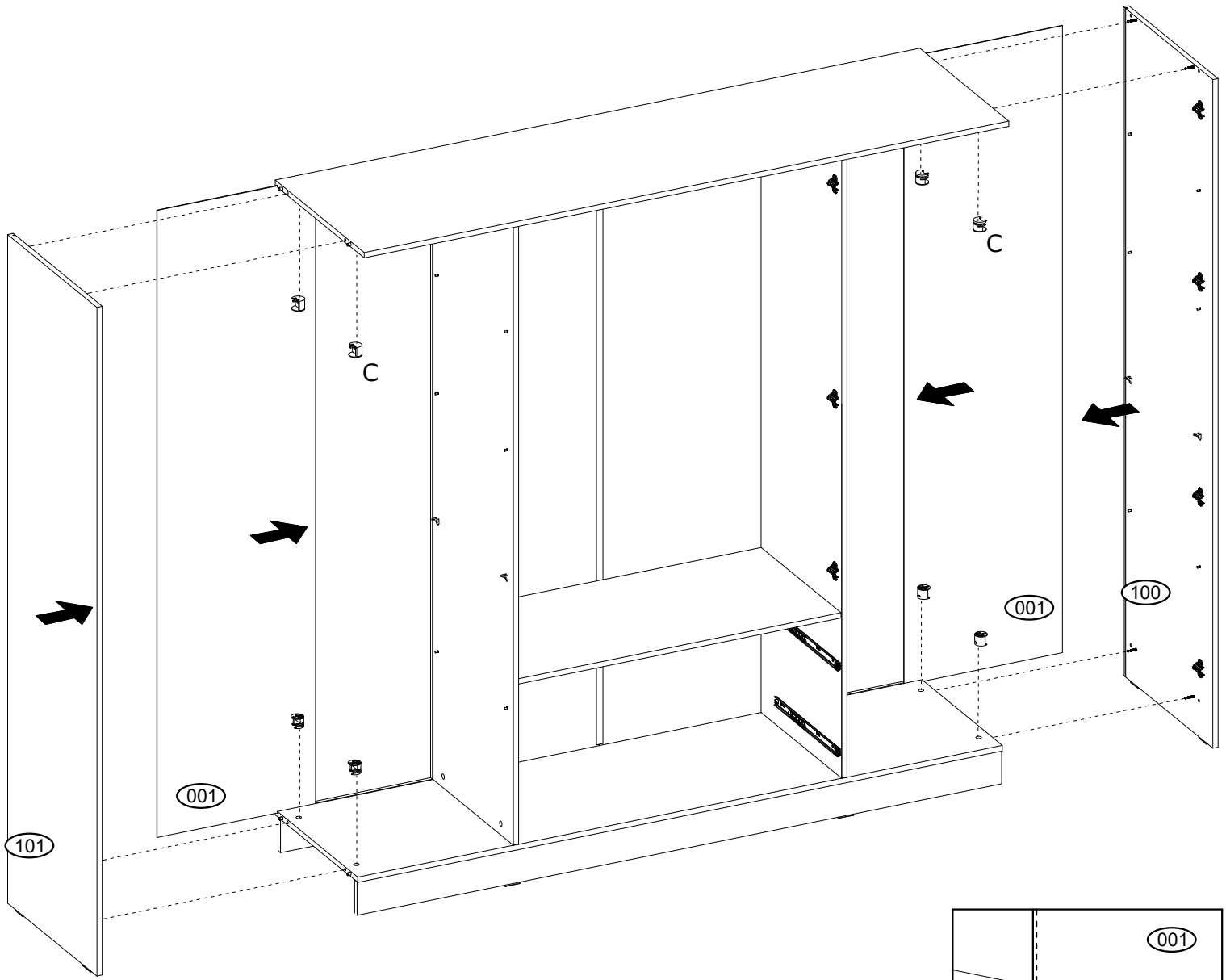
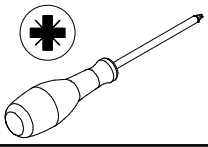

13

C Ø15x12 mm x8 3996



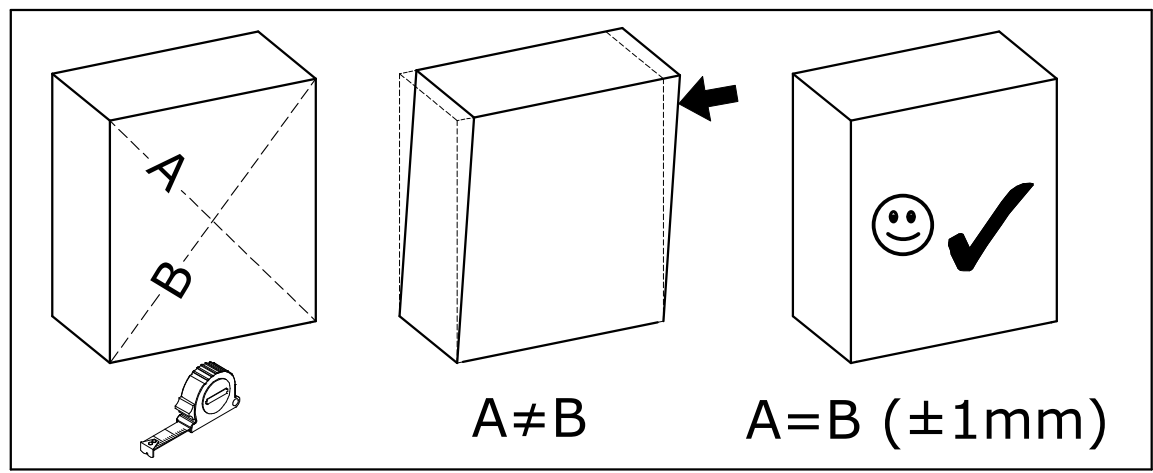
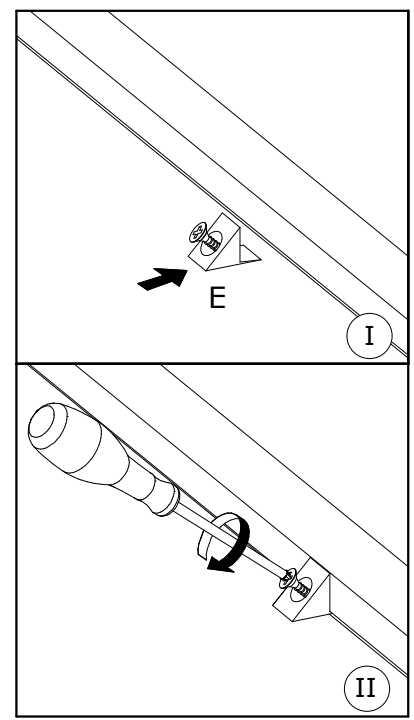
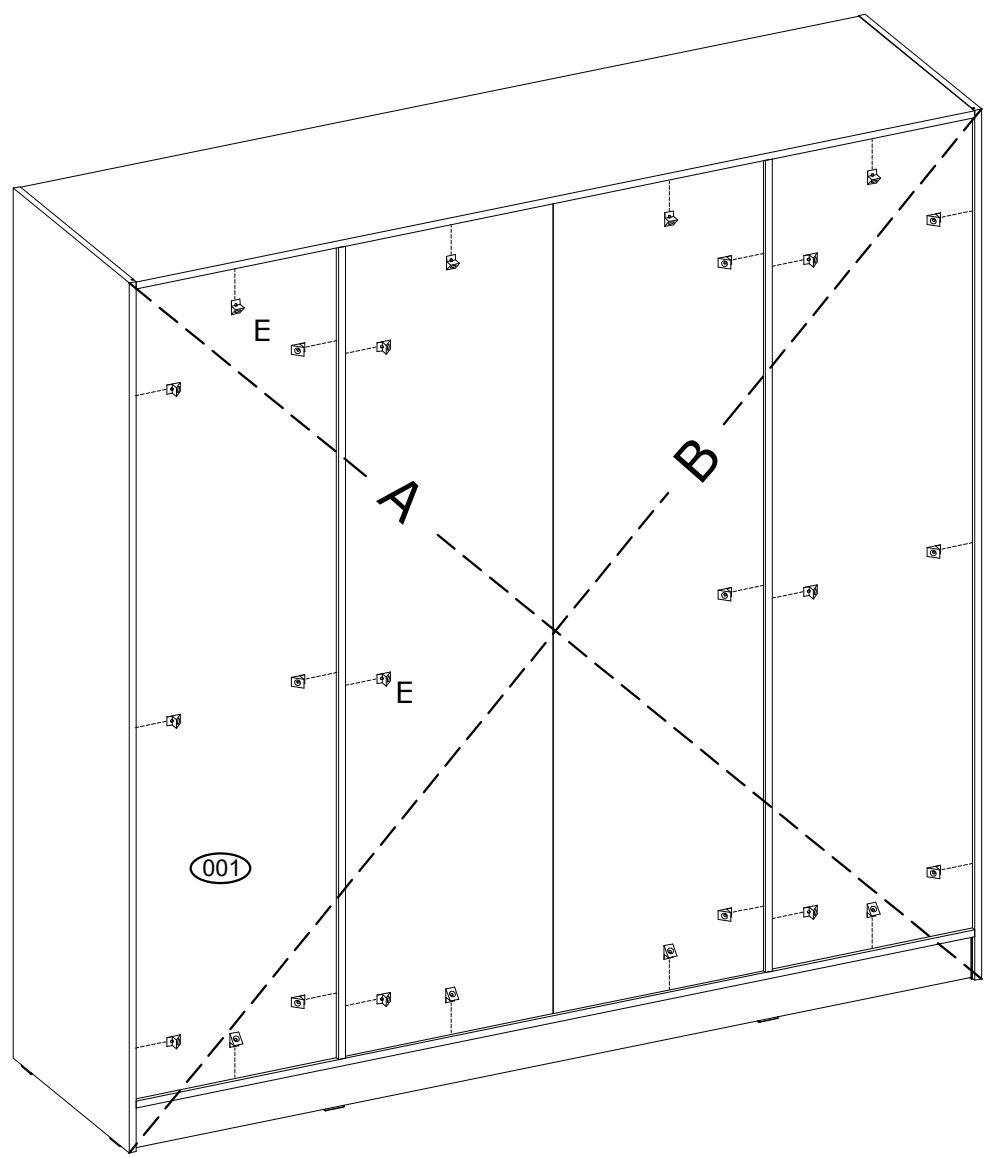
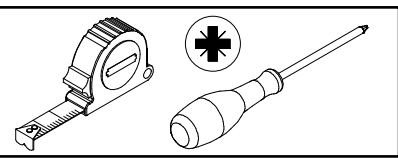

14

E 15x14x11 mm
x26
4044

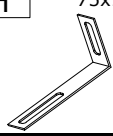

15

H	75x15x32 mm	K	Ø3,5x16 mm
	x2 71900		x4 3918

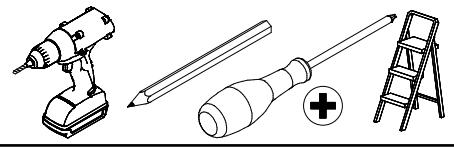

ACHTUNG - WARNING - ATTENTION - ATTENZIONE - AANDACHT - UWAGA - POZOR - POZOR - FIGYELEM - ATENȚIE - ДІККАТ - ВНИМАНИЕ - ПАЖЊА - PAŽNJA - POZOR - DĚMESIO - UZMANĪBU - TĀHELEPANU - ATENCIÓN- ATENÇÃO

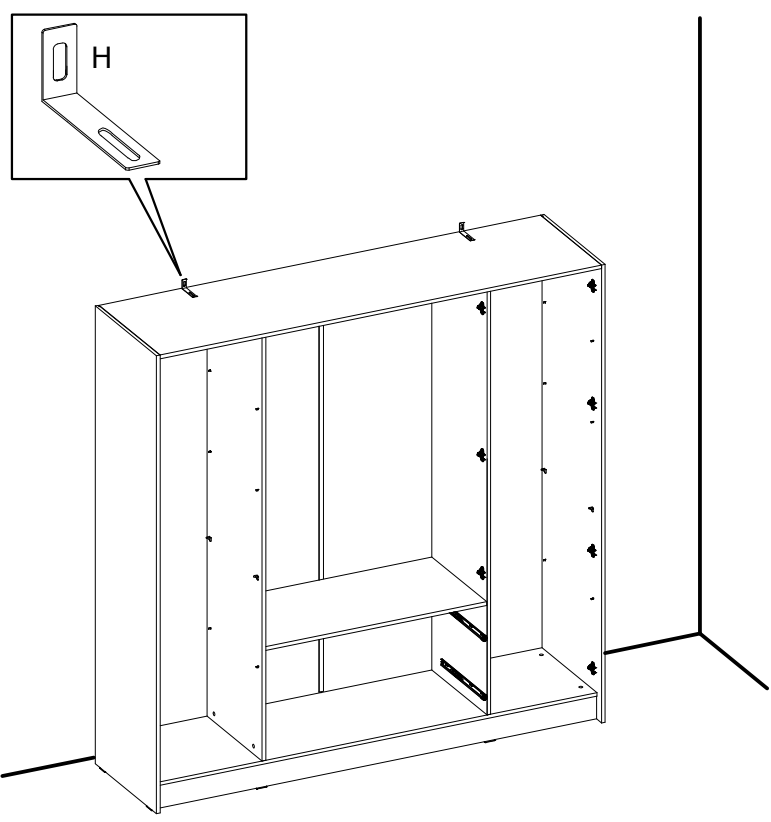

D - ACHTUNG: WARNUNG Umkippen zu vermeiden, muss dieses Produkt mit der mitgelieferten Wandhalterung verwendet werden.

GB - WARNING: WARNING In order to prevent overturning this product must be used with the wall attachment device provided.

FR - ATTENTION: AVERTISSEMENT Pour éviter le renversement, ce produit doit être utilisé avec le support de montage mural fourni.

IT - ATTENZIONE: AVVERTENZA Per evitare il ribaltamento, questo prodotto deve essere utilizzato con una staffa di montaggio a parete inclusa.

NL - AANDACHT: WAARSCHUWING Om kantelen te voorkomen, moet dit product worden gebruikt met de meegeleverde wandmontagebeugel.

PL - UWAGA: OSTRZEŻENIE Aby zapobiec przewróceniu, produkt ten musi być używany z dołączonym uchwytem do montażu ściennego.

CZ - POZOR: UPOZORNĚNÍ Aby se zabránilo převrácení, musí být tento výrobek používán s daným držákem pro montáž na stěnu.

SK - POZOR: POZORILLO Da bi preprečili prevračanje, je treba ta izdelek uporabljati s priloženim nosilcem za pritrditev na steno.

HU - FIGYELEM: FIGYELMEZTETÉS A billenés megakadályozása érdekében ezt a terméket a mellékelt falirögzítő konzollal kell használni.

RO - ATENȚIE: AVERTISMENT Pentru a preveni răsturnarea, acest produs trebuie să fie utilizat cu suportul de montare pe perete furnizat.

TR - DİKKAT: UYARI Devrilmeyi önlemek için, bu ürün birlikte verilen duvara montaj braketi ile kullanılmalıdır.

RU - ВНИМАНИЕ: ПРЕДУПРЕЖДЕНИЕ Для предотвращения опрокидывания, этот продукт необходимо использовать с прикрепленным кронштейном для настенного монтажа.

SRB - ПАЖЊА: УПОЗОРЕЊЕ Да бисте спречили превртање, овај производ мора да се користи са укљученом зидним заградом за монтажу.

HR - PAŽNJA: UPOZORENJE Da biste spriječili prevrtanje, ovaj se proizvod mora koristiti s priloženim zidnim nosačem.

SL - POZOR: OPOZORNENIE Aby sa zabránilo prevráteniu, tento výrobok sa musí používať s dodanou nástennou montážnou konzolou.

LT - DĚMESIO: ĮSPĖJIMAS Kad šis gaminyš neapvirštų, jis turi būti naudojamas su pridėdamu sieniniu laikikliu.

LV - UZMANĪBU: BRĪDINĀJUMS Lai novērstu apgāšanos, šis izstrādājums jāizmanto kopā ar pievienoto sienas stiprinājuma kronšteinu.

EE - TĀHELEPANU: HOIATUS Kukkumise vältimiseks tuleb seda toodet kasutada koos kaasasoleva seinakinnitusklambriaga.

ES - ATENCIÓN! ADVERTENCIA Para evitar que se vuelque, este producto debe utilizarse con el soporte de montaje en pared proporcionado.

PT - ATENÇÃO! AVISO Para evitar o tombamento, este produto deve ser utilizado com o suporte de montagem na parede fornecido.

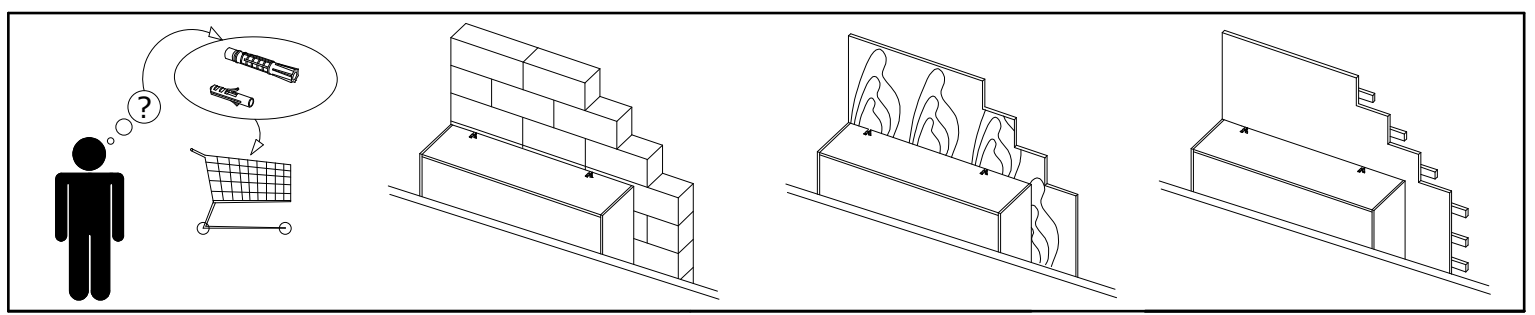
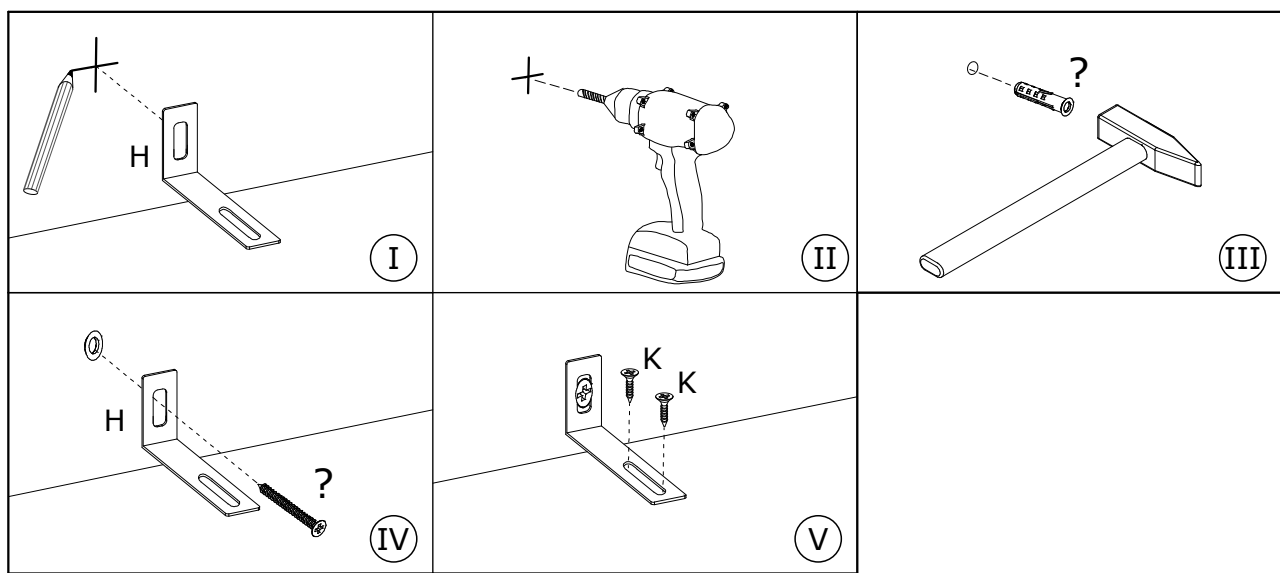

16

A	Ø8x30 mm			x4	92597	
----------	----------	--	--	----	-------	--

x2

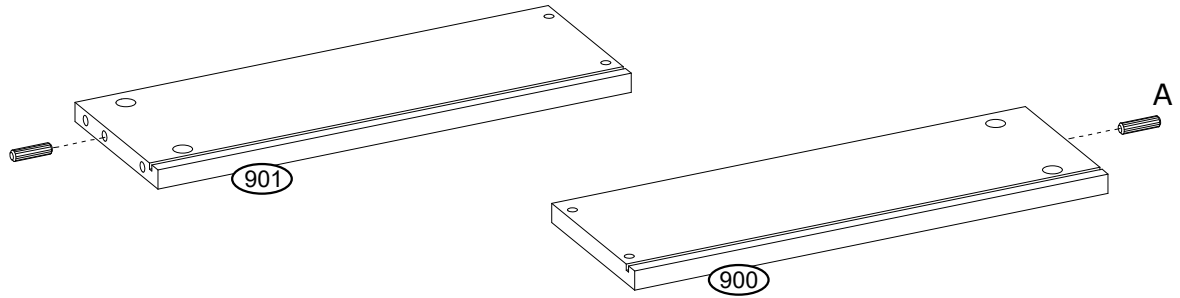

17

T	Ø6,4x50 mm			x8	3884	IM	4 mm	x1	3984
----------	------------	--	---	----	------	-----------	------	----	------

x2

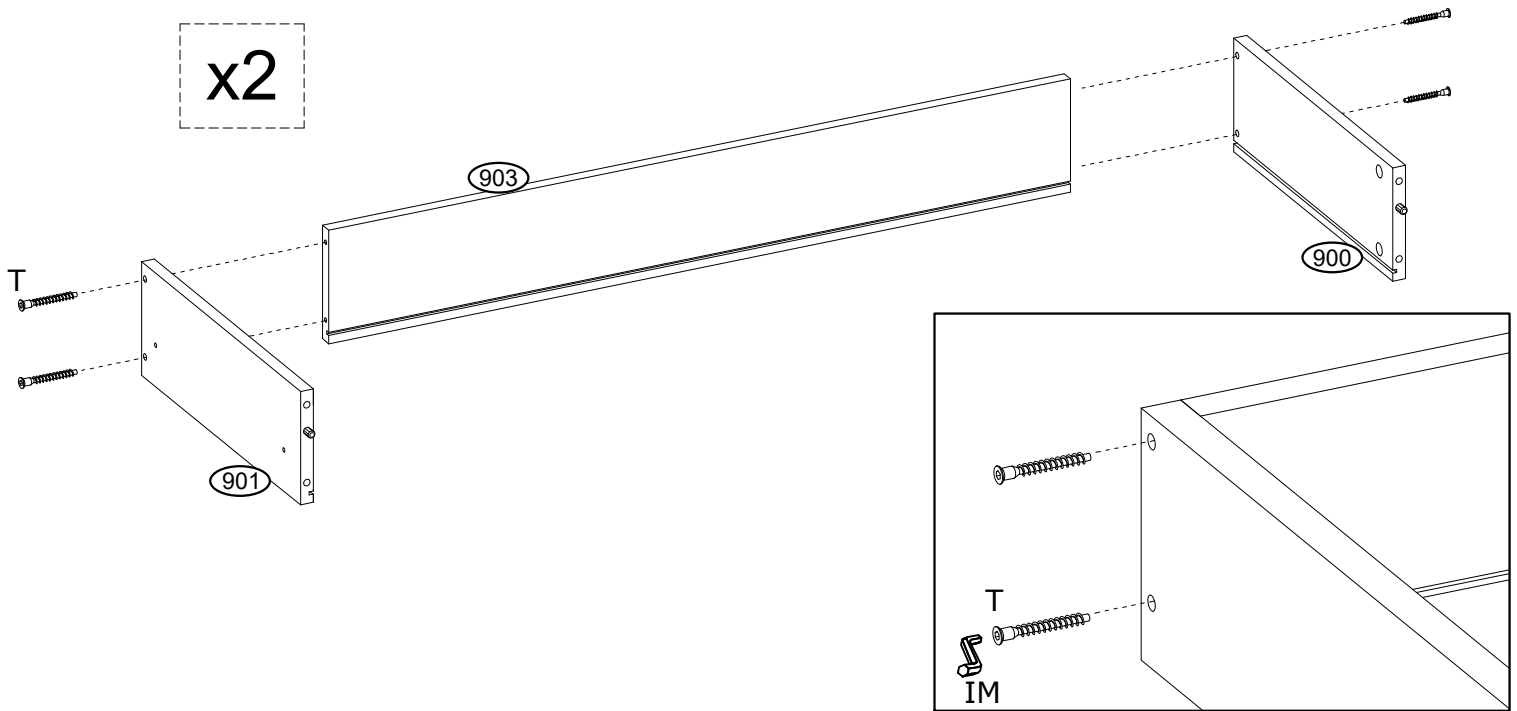

18

B	Ø6,5x36,5 mm			x8	4066	
----------	--------------	--	---	----	------	---

x2

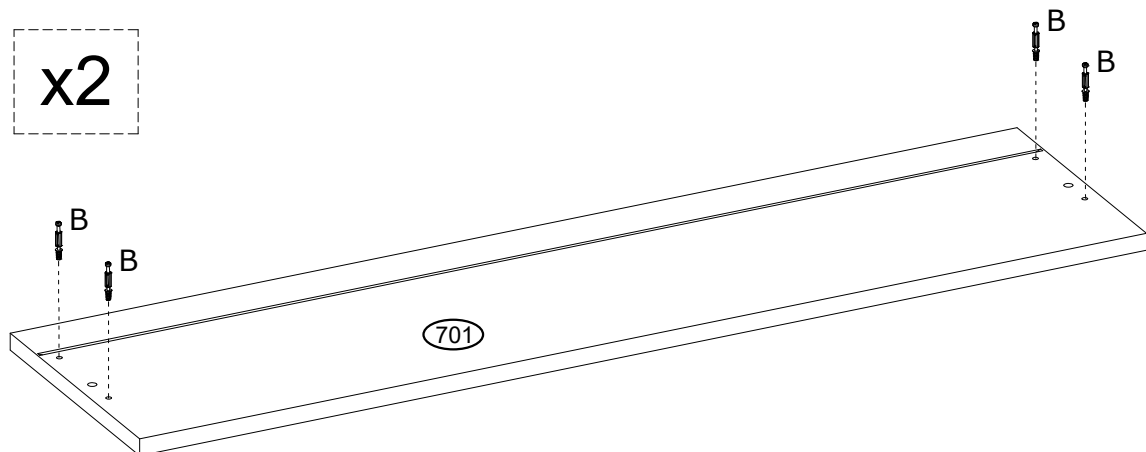

19

C	Ø15x12 mm				
	x8	3996			

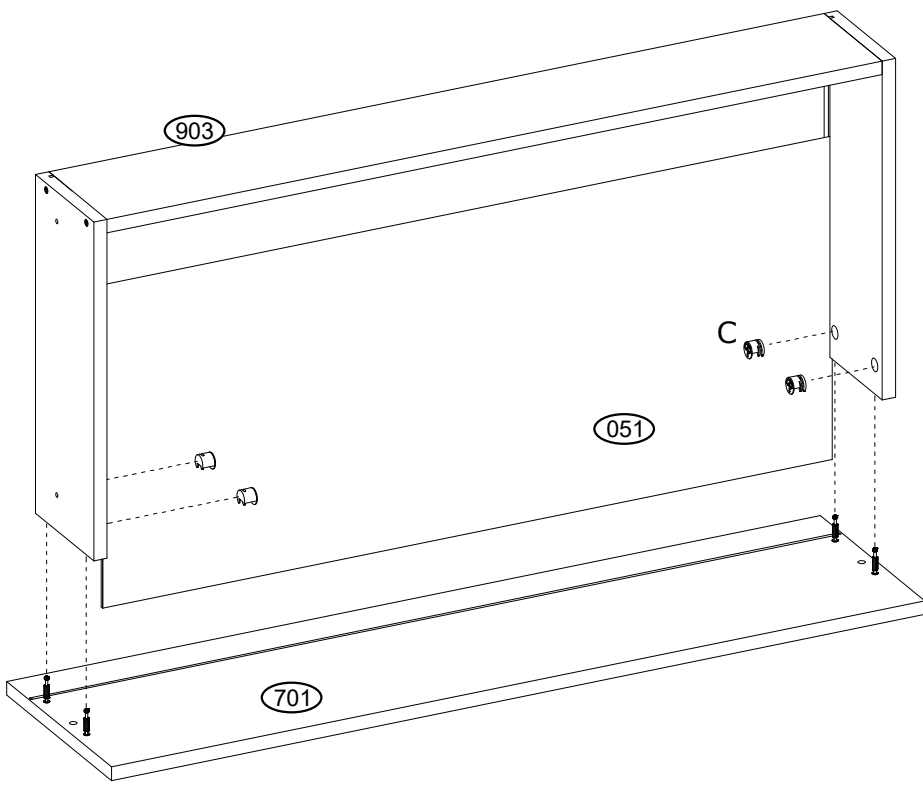

x2

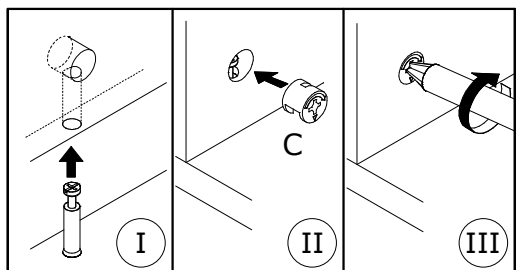

20

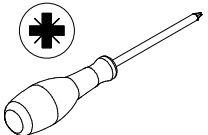
K	Ø3,5x16 mm	WS1	384 mm		
	x4	3918		x2	69509
					

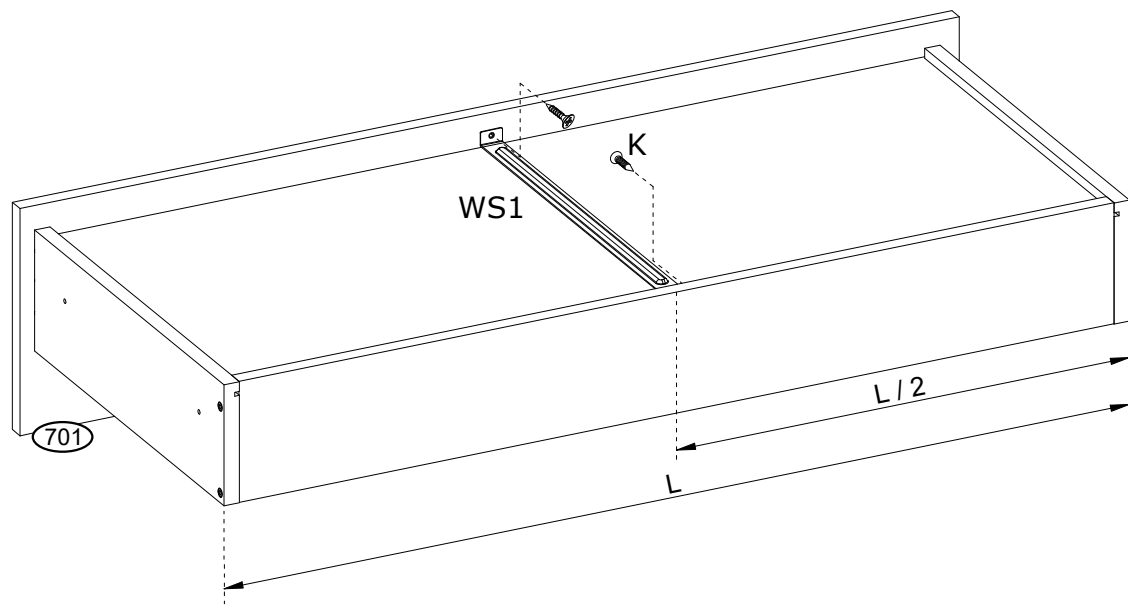

x2

21

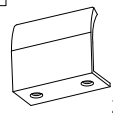
UC	50 mm
	x2
	278439

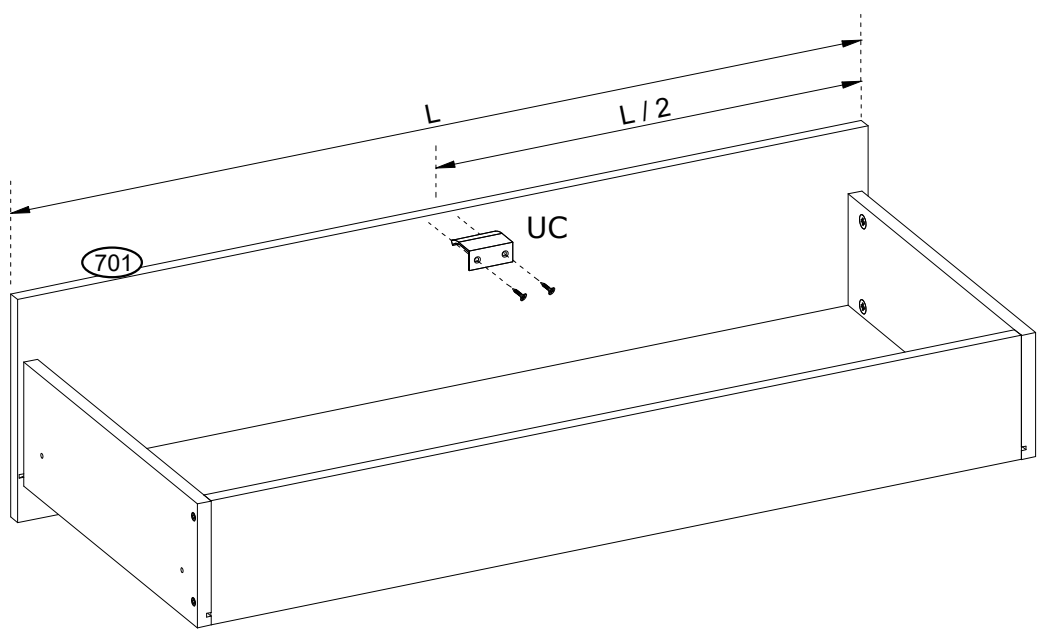
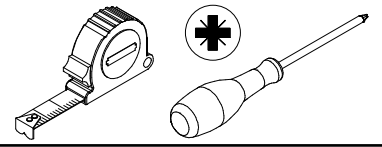

22

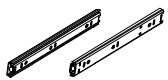
K	Ø3,5x16 mm	PR	L-400 mm
	x8		x2
	3918		252763

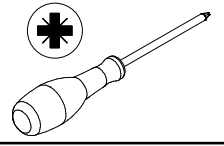

x2

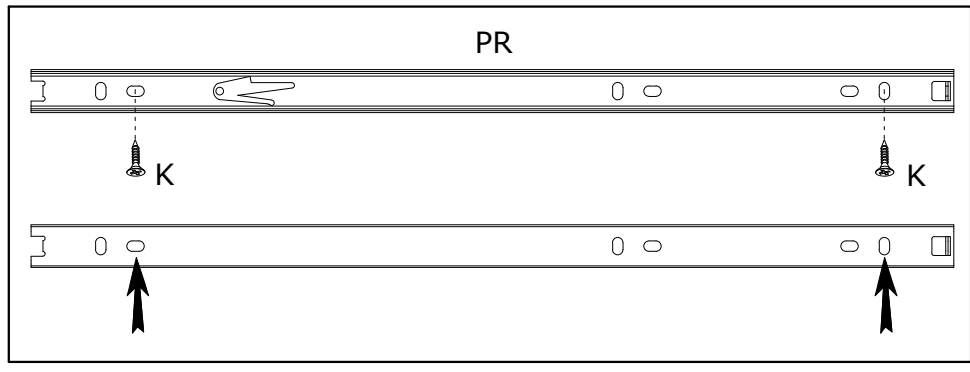
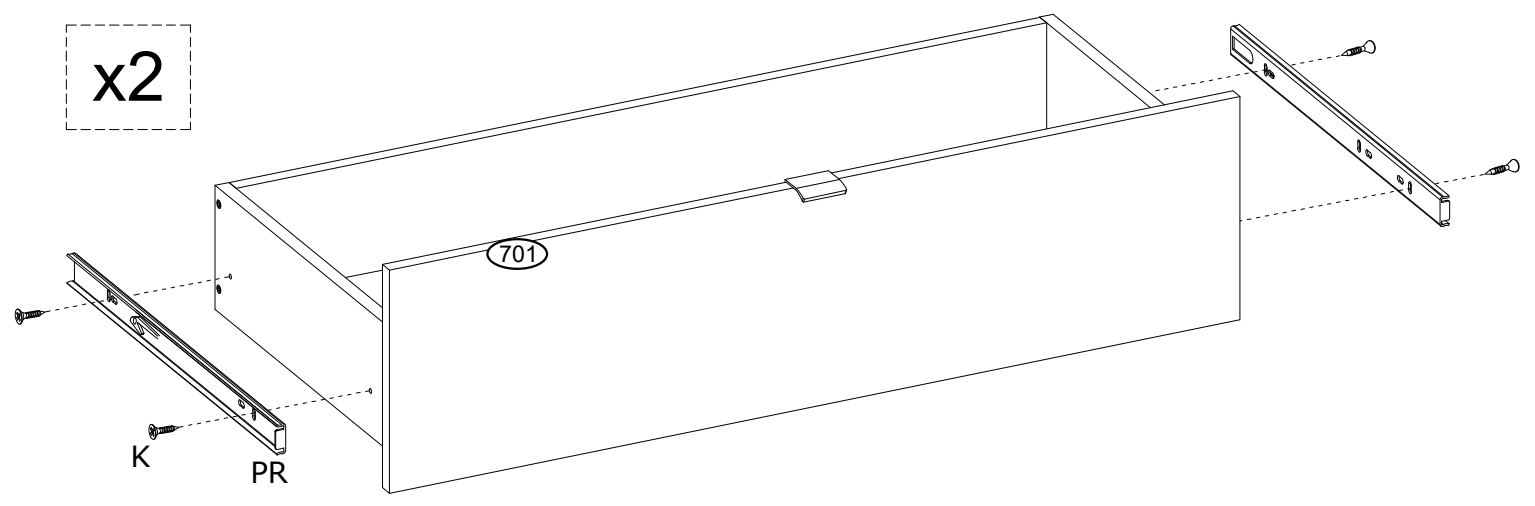

23

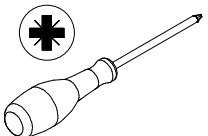
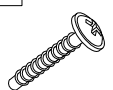
M	Ø4x25 mm		
	x56		
	145556		

x2

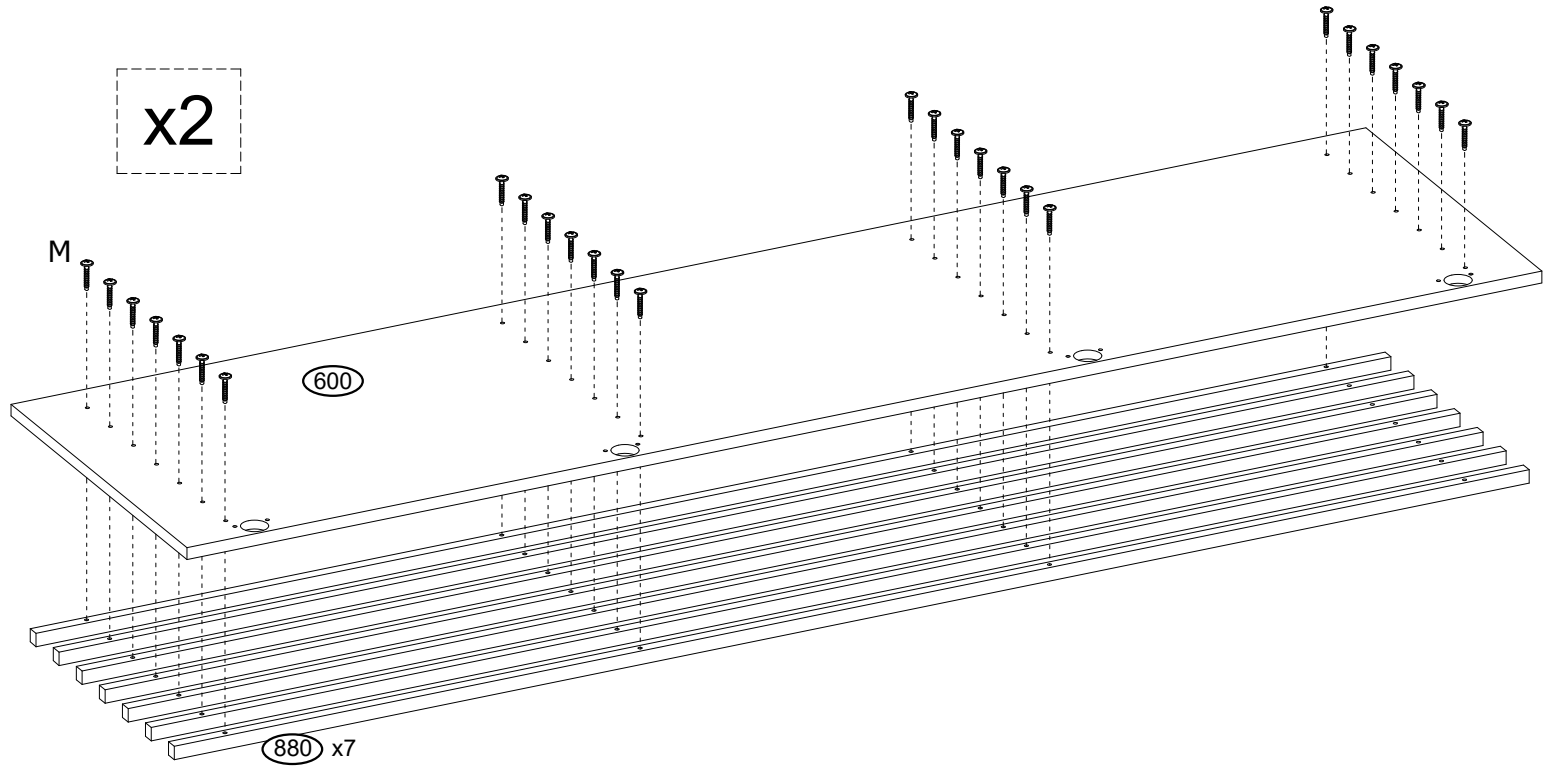

24

K	Ø3,5x16 mm	BN15	Ø35 mm, KR15	
	x16		x8	
	3918		68850	

x2

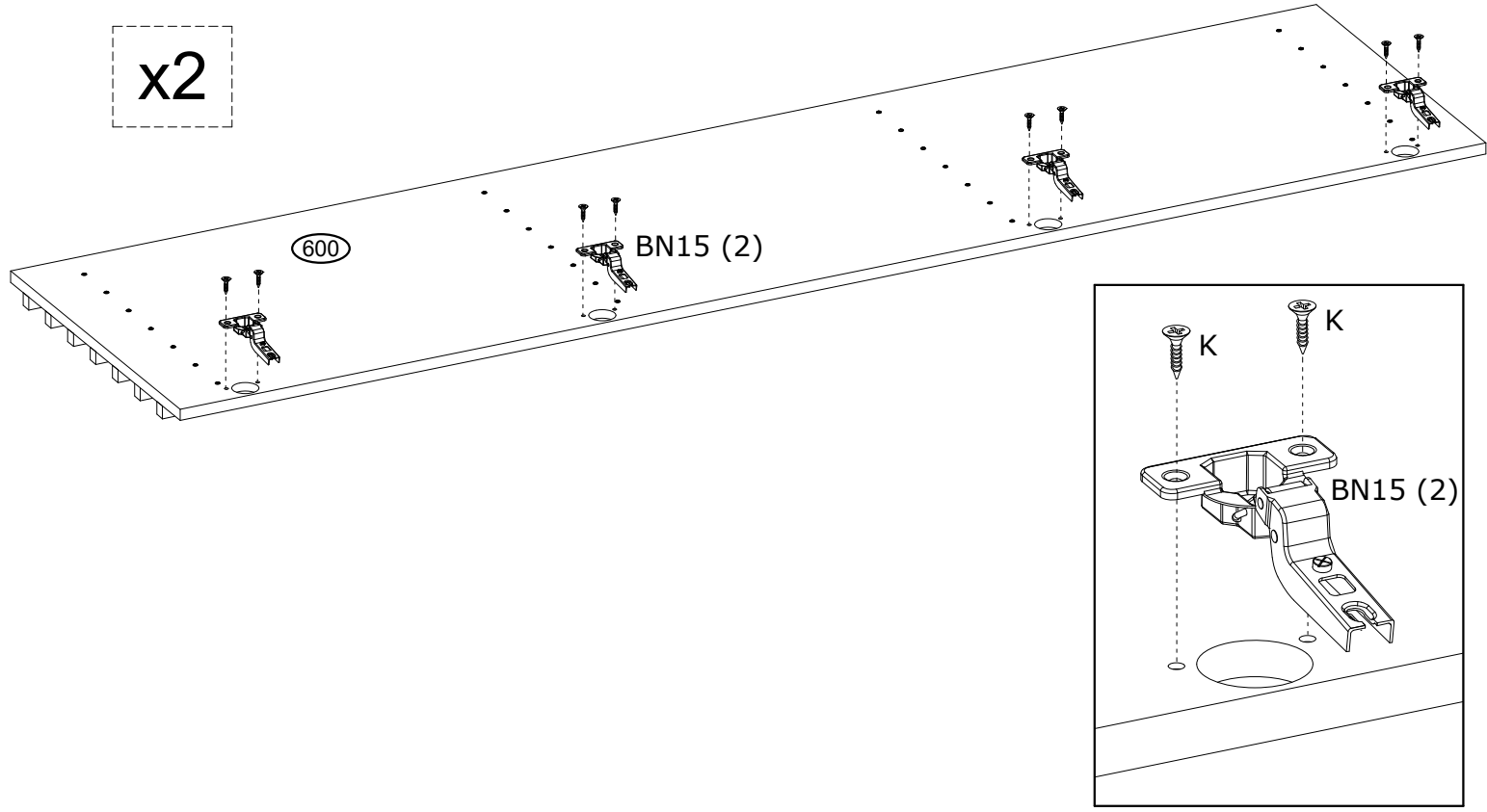

25

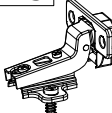
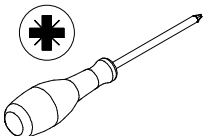
K	Ø3,5x16 mm	BN15	Ø35 mm, KR15		x12 3918		x6 68850	
----------	------------	-------------	--------------	--	--------------------	--	--------------------	--

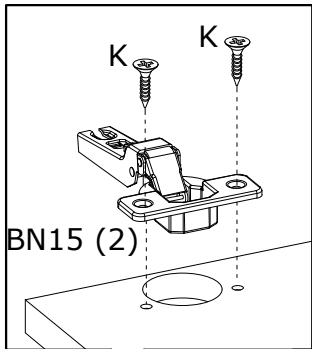

x2

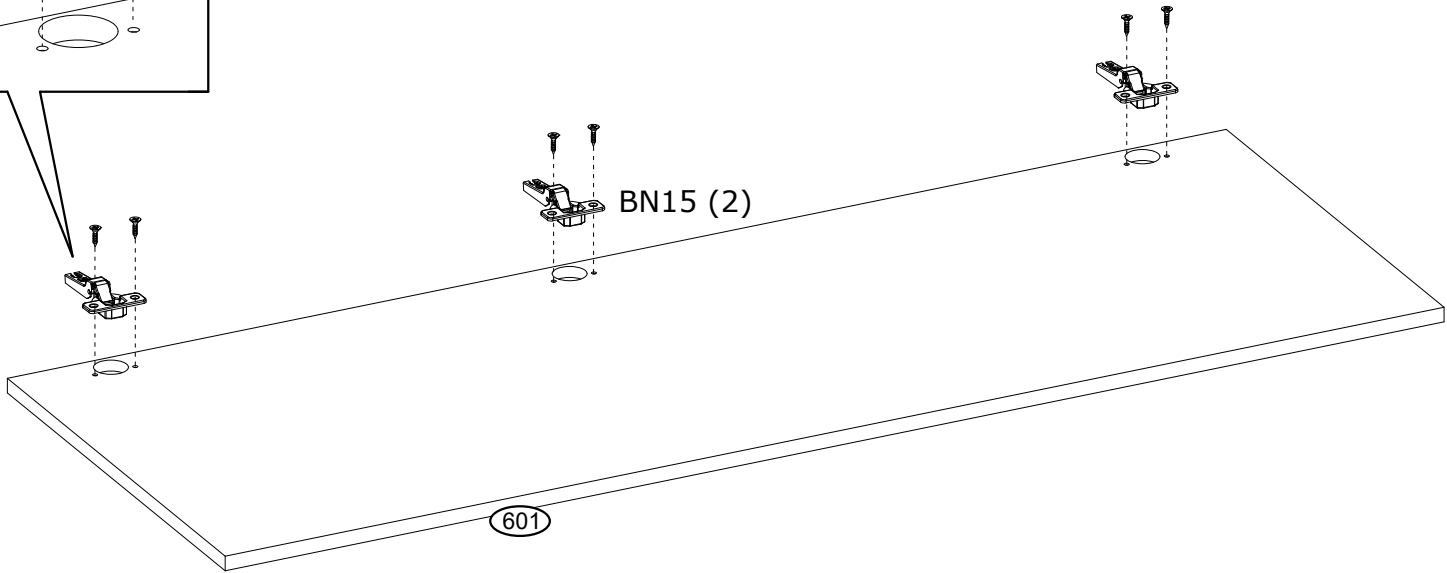

26

UC	50 mm		x1 278439		
-----------	-------	---	---------------------	---	---

x1

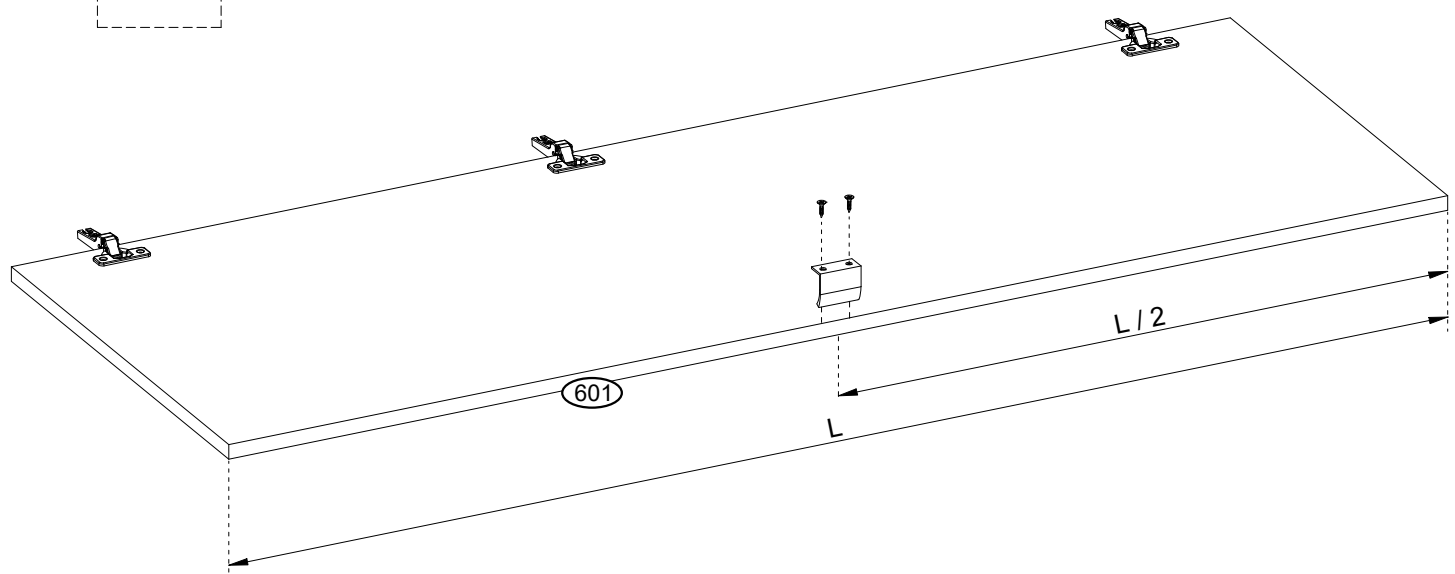

27

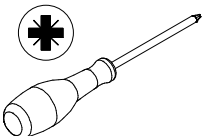
K	Ø3,5x16 mm	DR	978 mm	
	x8 3918		x1 67750	

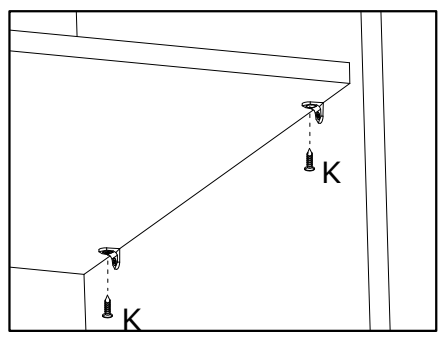
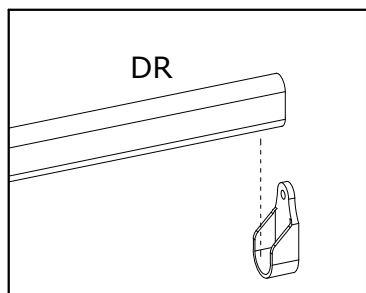
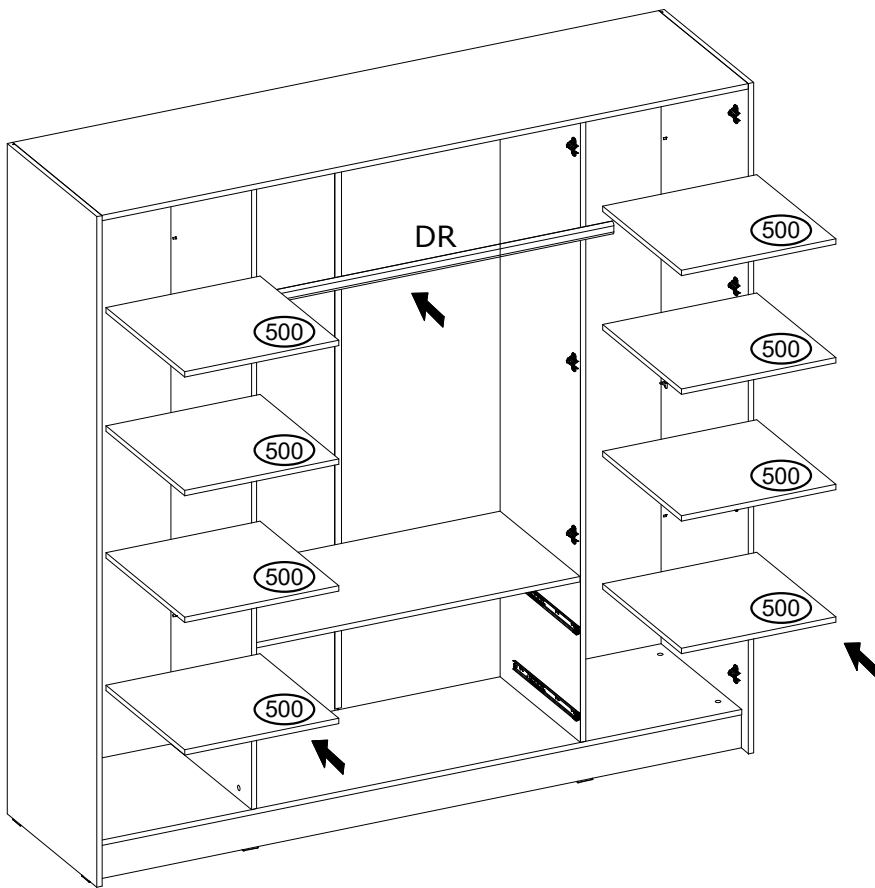

28

K	Ø3,5x16 mm			
	x4 3918			

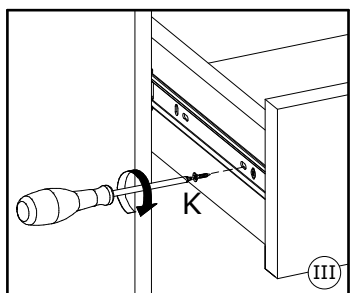
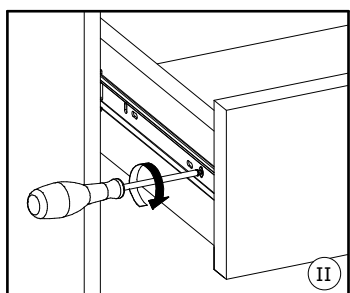
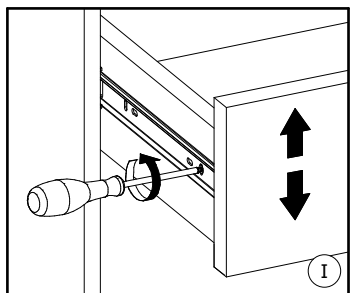
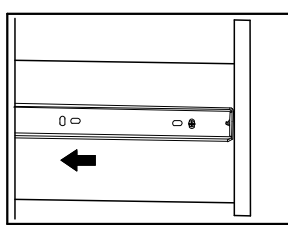
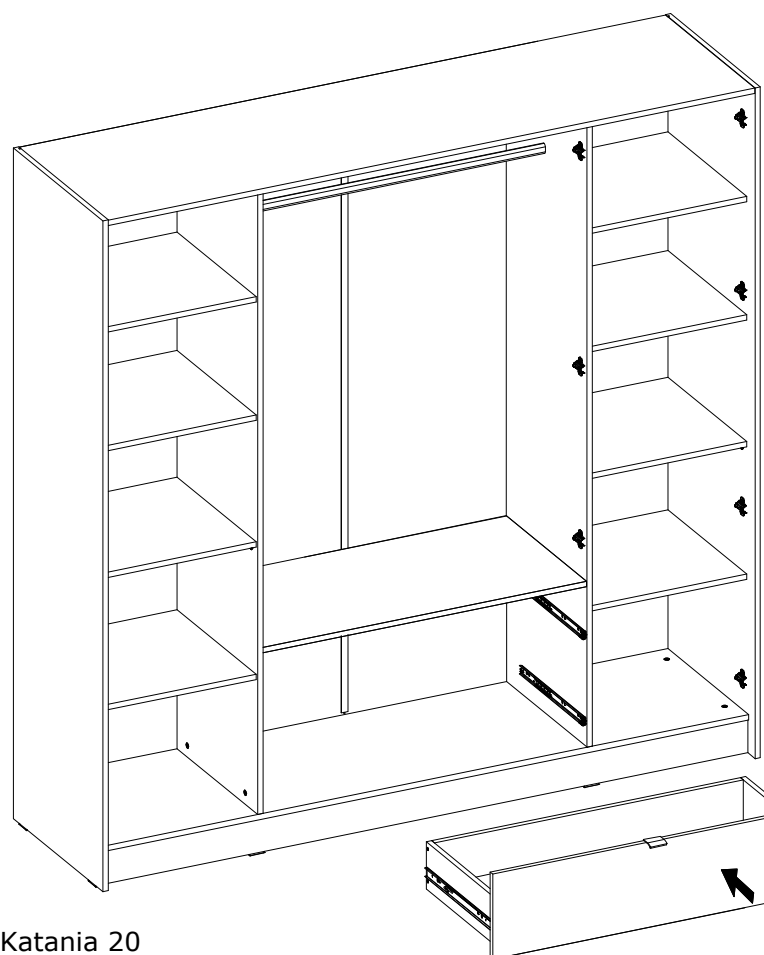

29

D
Ø20 mm
x24
136239

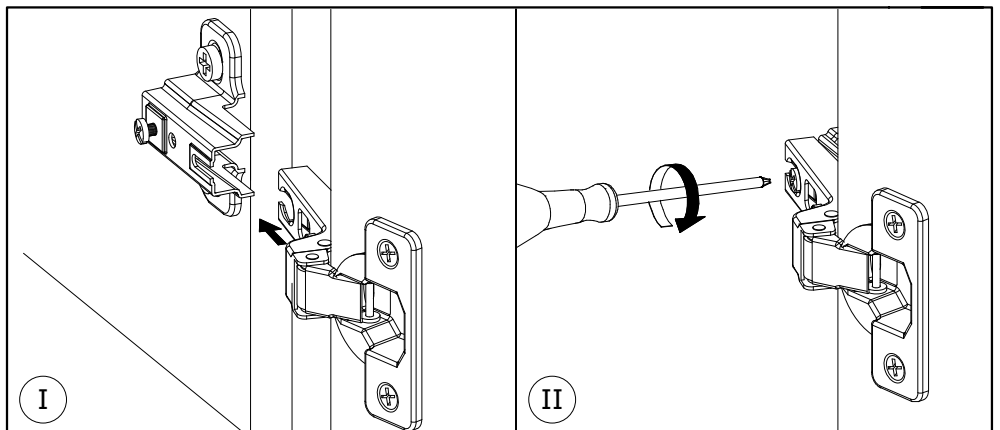
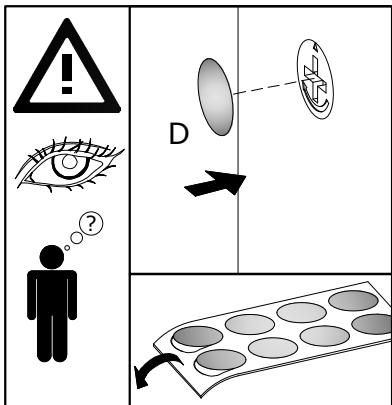
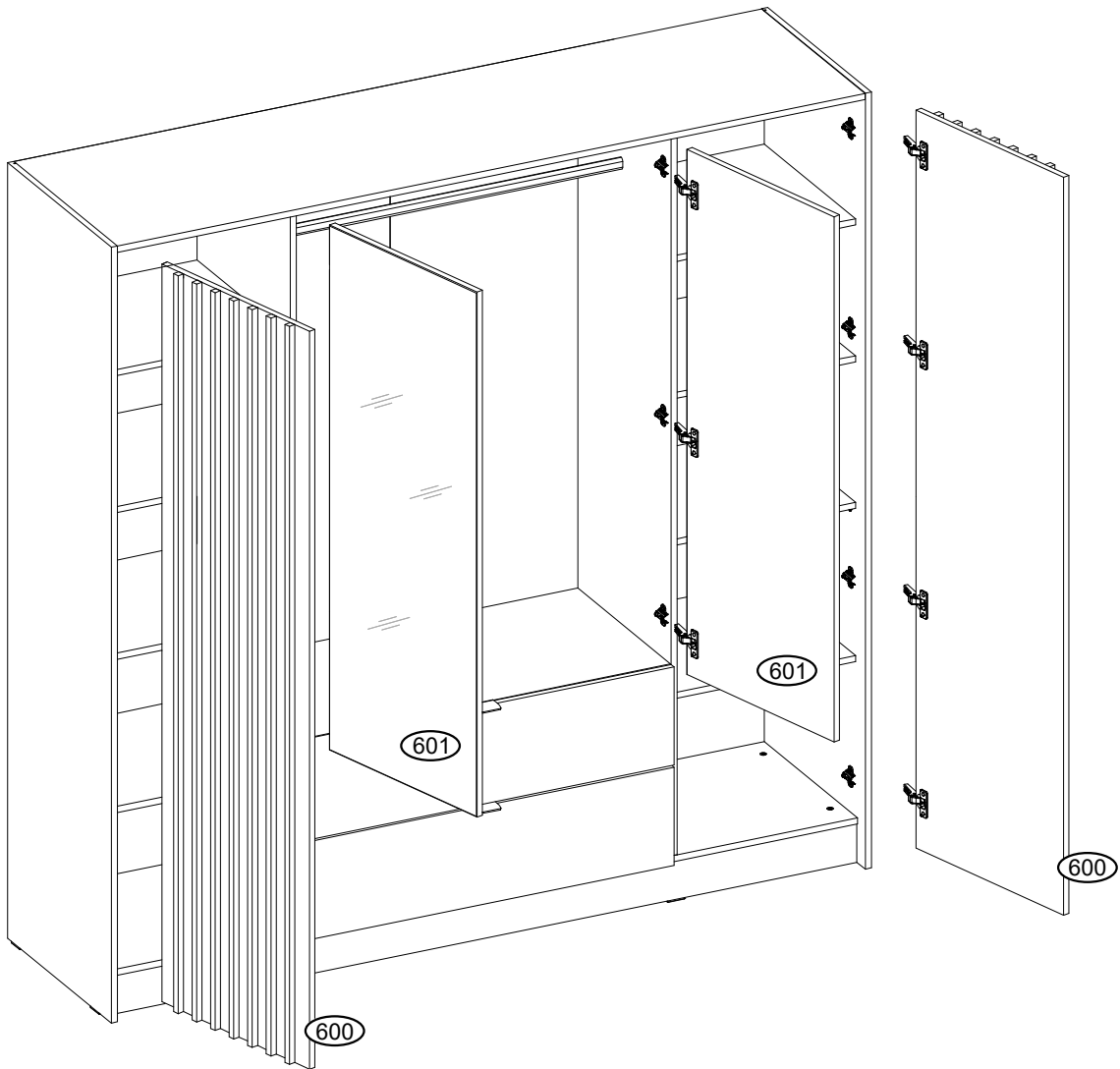
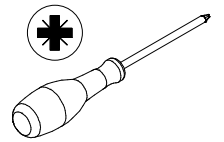

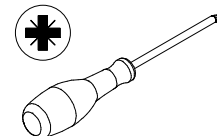

Türen einstellen (Scharniere justieren)

Adjusting the door (adjusting the hinges)

Régler les portes (ajuster les charnières)

Sistemare le porte (regolare le cerniere)

Deuren instellen (scharnieren afstellen)

Nastawić drzwi (wyregulować zawiasy)

Vyrovnaťte dvířka (seřid'ťte závěsy)

Nastavenie dverí (nastavenie závesov)

Állítsa be az ajtókat (állítsa be a zsanérokat)

Reglare uși (ajustare balamale)

Kapilarin ayarlanması (menteselerin seviye ayarı)

Регулировка дверей (регулировка шарнира)

Поставите врата (подесите шарке)

Postavite vrata (podesite šarke)

Nastavenie dverí (nastavenie závesov)

Sureguliuokite duris (sureguliuokite vyrius)

Pielāgojiet durvis (noregulējiet eņģes)

Reguleeri uks (reguleeri hinged)

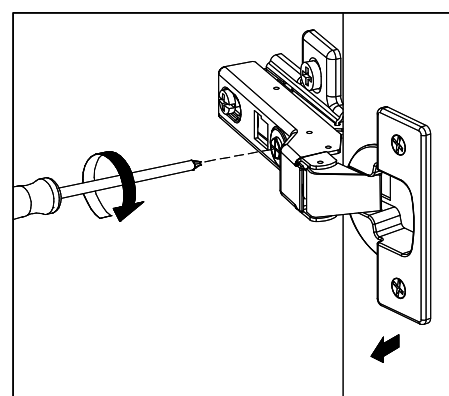
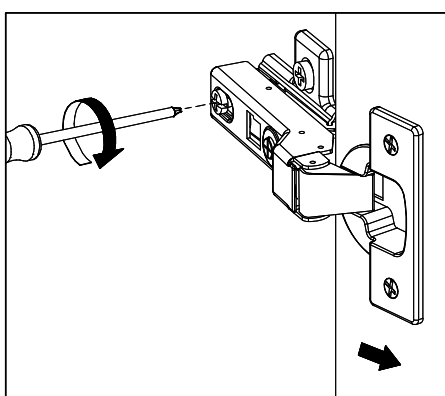
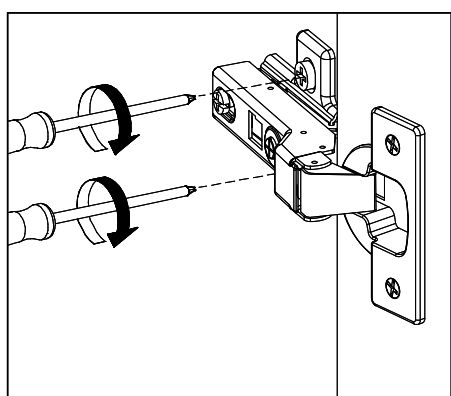
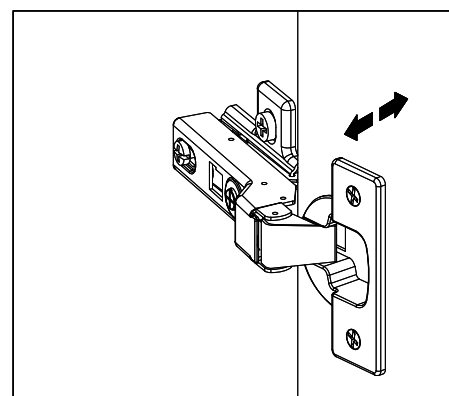
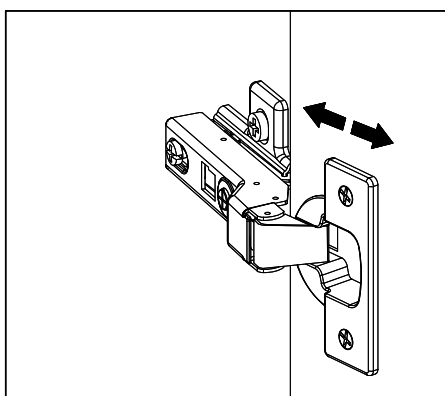
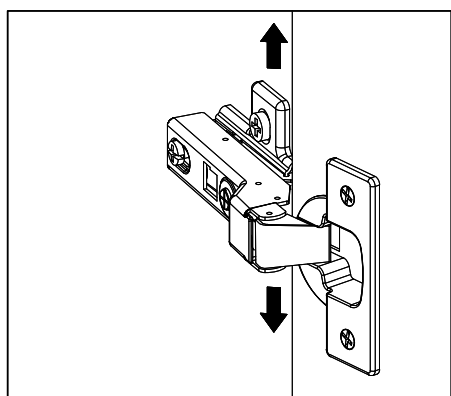
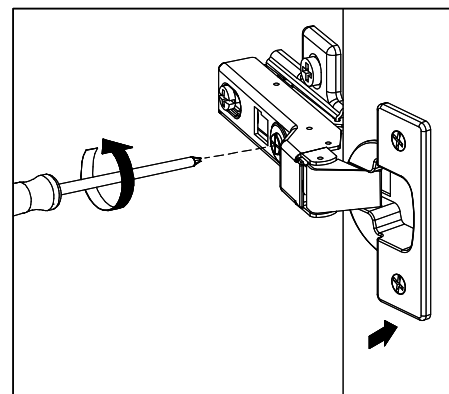
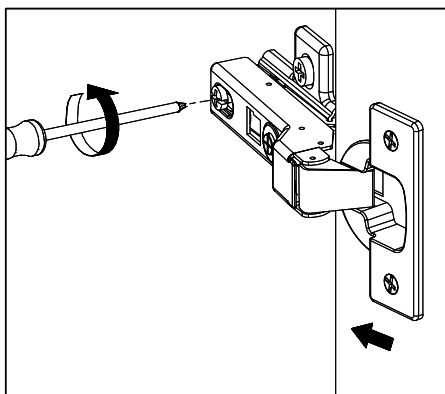
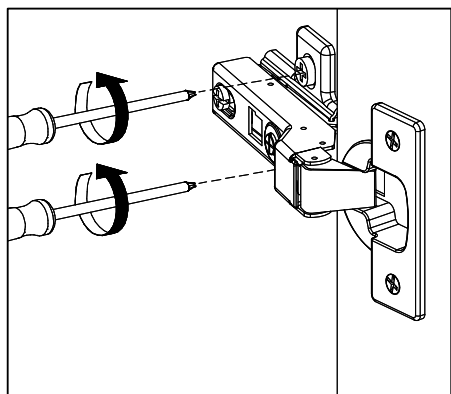
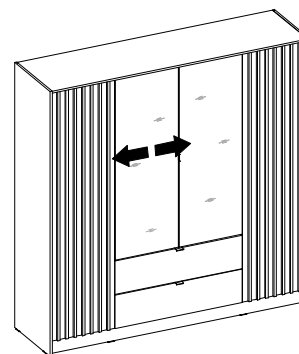
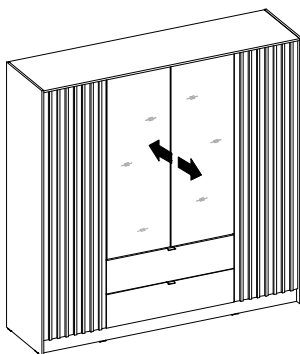
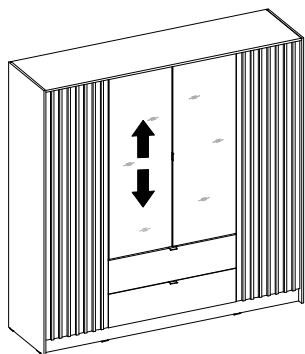

- | | |
|--|--|
| D Sicherheits- und Pflegehinweise | GB Safety and maintenance tips |
| FR Conseils de sécurité et d'entretien | IT Consigli per la sicurezza e la manutenzione |
| NL Veiligheids- en onderhoudstips | PL Wskazówki dotyczące bezpieczeństwa i konserwacji |
| CZ Tipy pro bezpečnost a údržbu | SK Tipy na bezpečnosť a údržbu |
| HU Biztonsági és karbantartási tanácsok | RO Sfaturi de siguranță și întreținere |
| TR Güvenlik ve bakım ipuçları | RU Советы по безопасности и обслуживанию |
| ES Instruções de segurança e manutenção | PT Instruções de segurança e manutenção |
| SRB Савети за безбедност и одржавање | HR Savjeti za sigurnost i održavanje |
| SL Nasveti za varnost in vzdrževanje | LT Saugos ir priežiūros patarimai |
| LV Drošības un apkopes padomi | EE Ohutus- ja hooldusnõuanded |
| BA Savjeti za sigurnost i održavanje | BG Съвети за безопасност и поддръжка |

